



SONIC ARTS

Acoustic Design

PORTFOLIO



A Sonic Arts é uma empresa de design acústico com mais de 25 anos de atuação em vários continentes, focada na integração harmônica de arquitetura e som através de soluções inovadoras e customizadas.





Nossos serviços incluem:

- Acústica Interna
- Isolamento de vibrações
- Áudio e Vídeo
- Ar Condicionado
- Alinhamento de Sistemas de Áudio

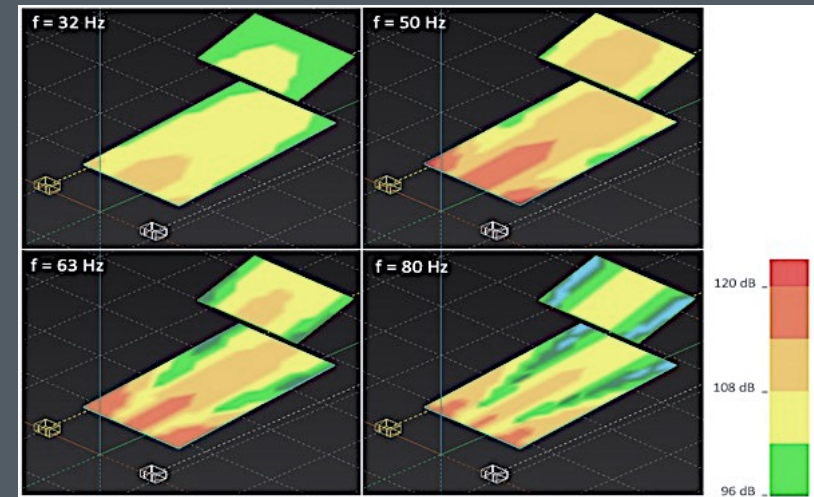
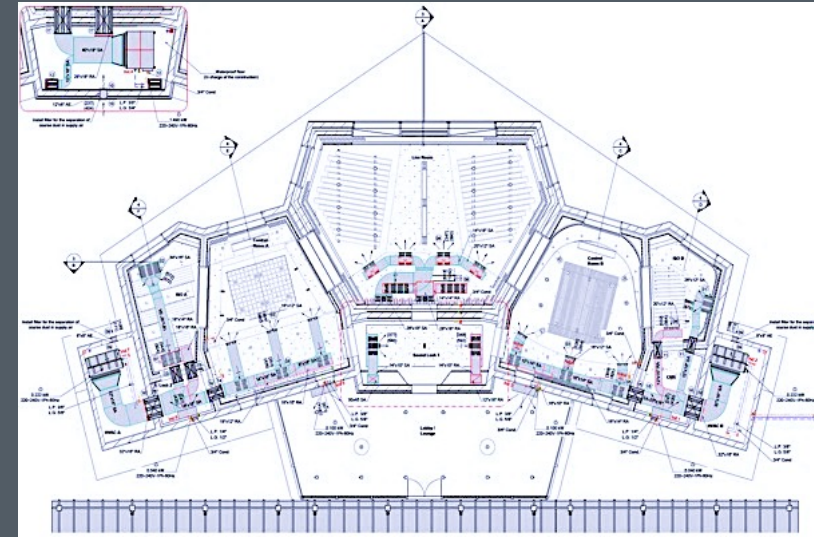

Figure 301.2 – Sound Pressure Levels for subwoofer configuration # 3



STUDIOS



ZHEJIANG CONSERVATORY OF MUSIC

Hangzhou, China

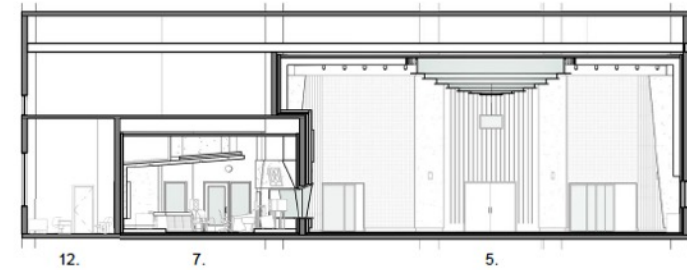
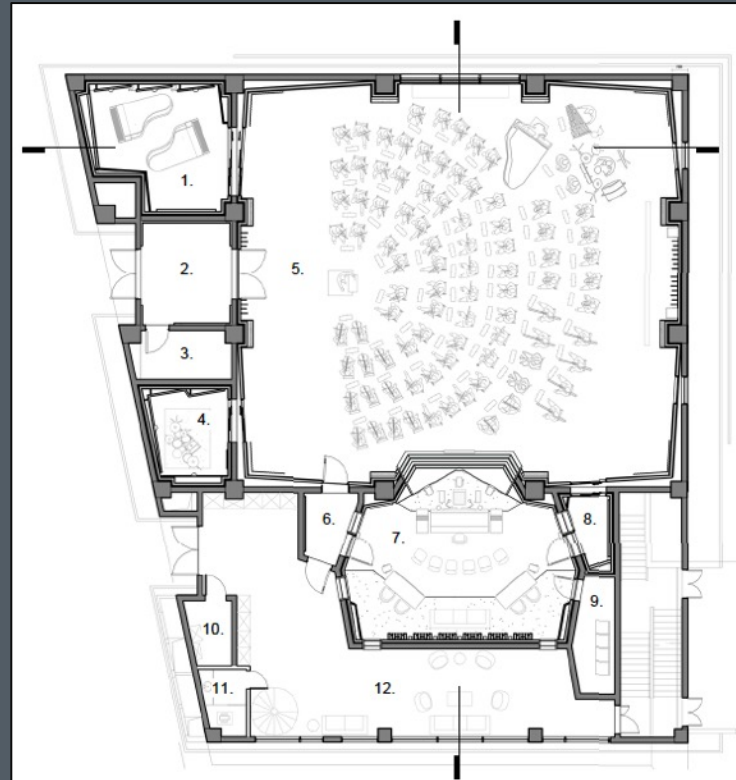
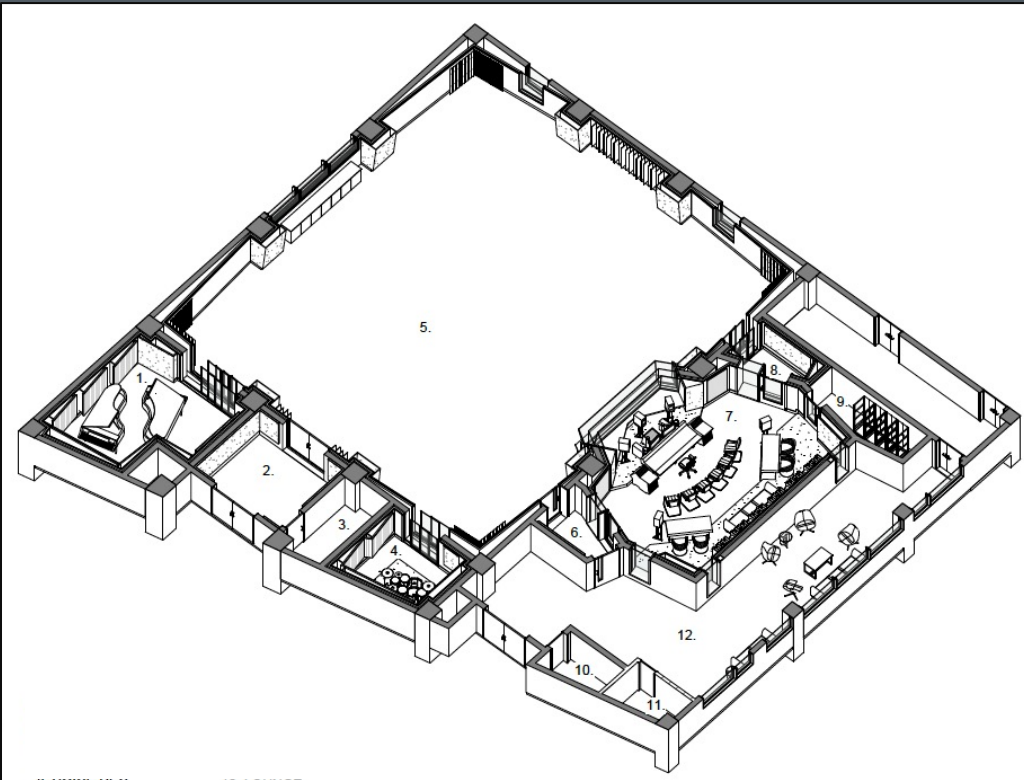

SECTION 1

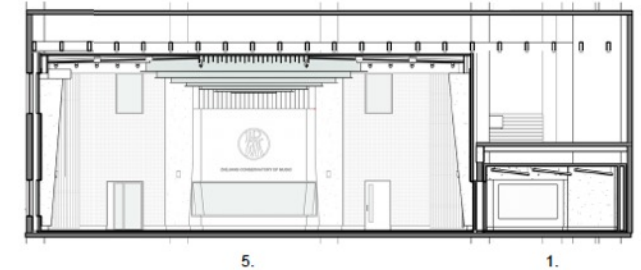



ZHEJIANG CONSERVATORY OF MUSIC

Hangzhou, China



Control Room



Studio



SONASTÉRIO

Nova Lima , Brasil

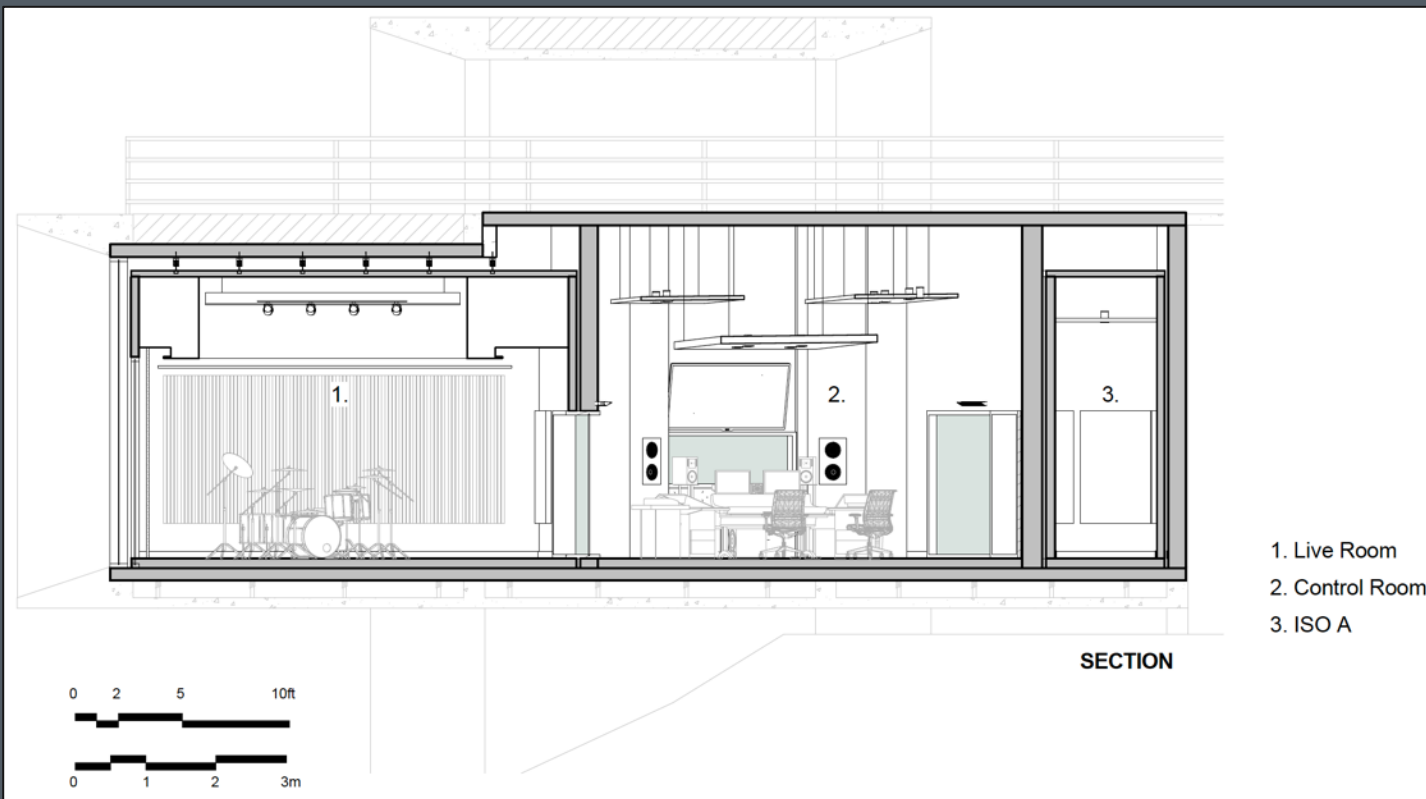
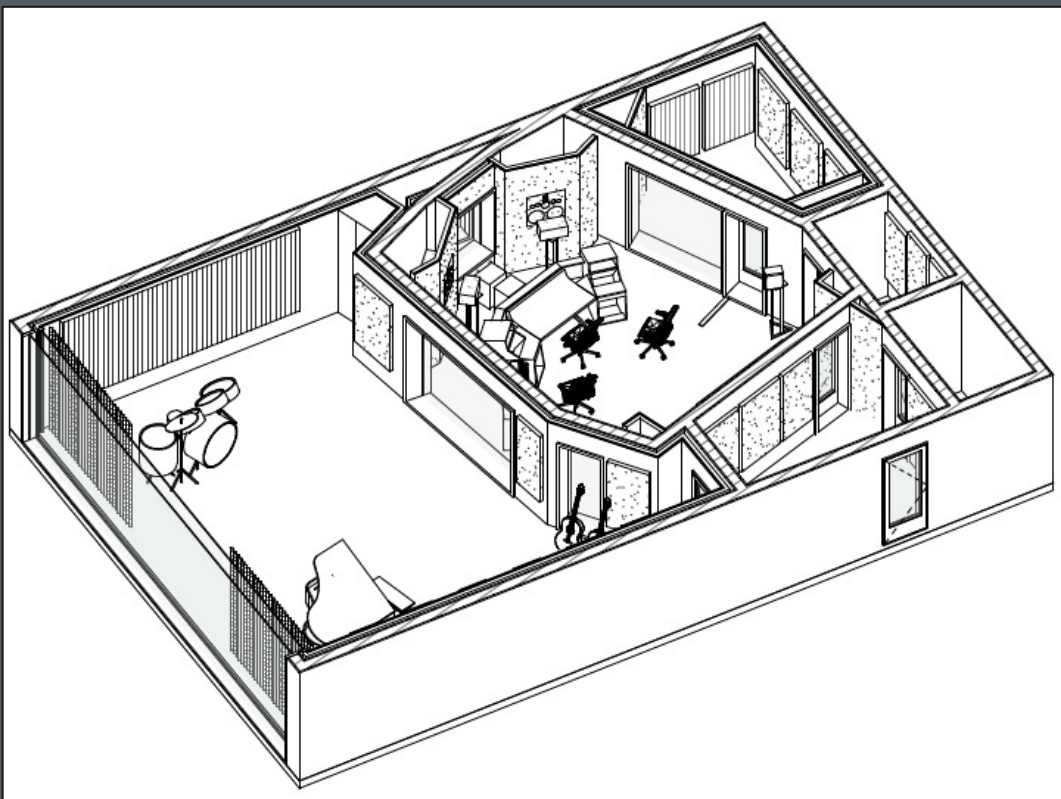



SONASTÉRIO

Nova Lima , Brasil



Control Room



Studio



ESPM (Escola Superior de Propaganda e Marketing)

São Paulo, Brasil

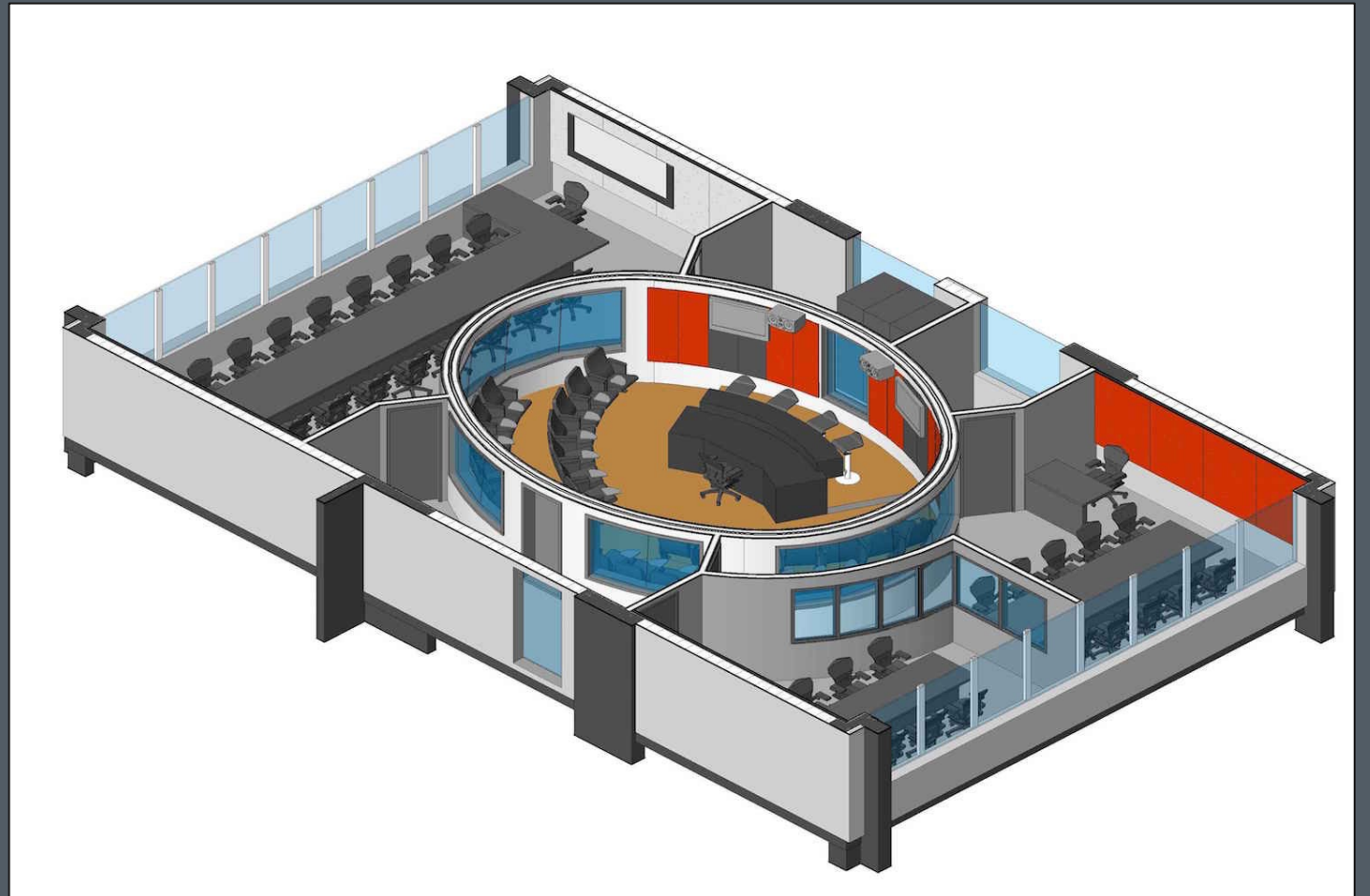
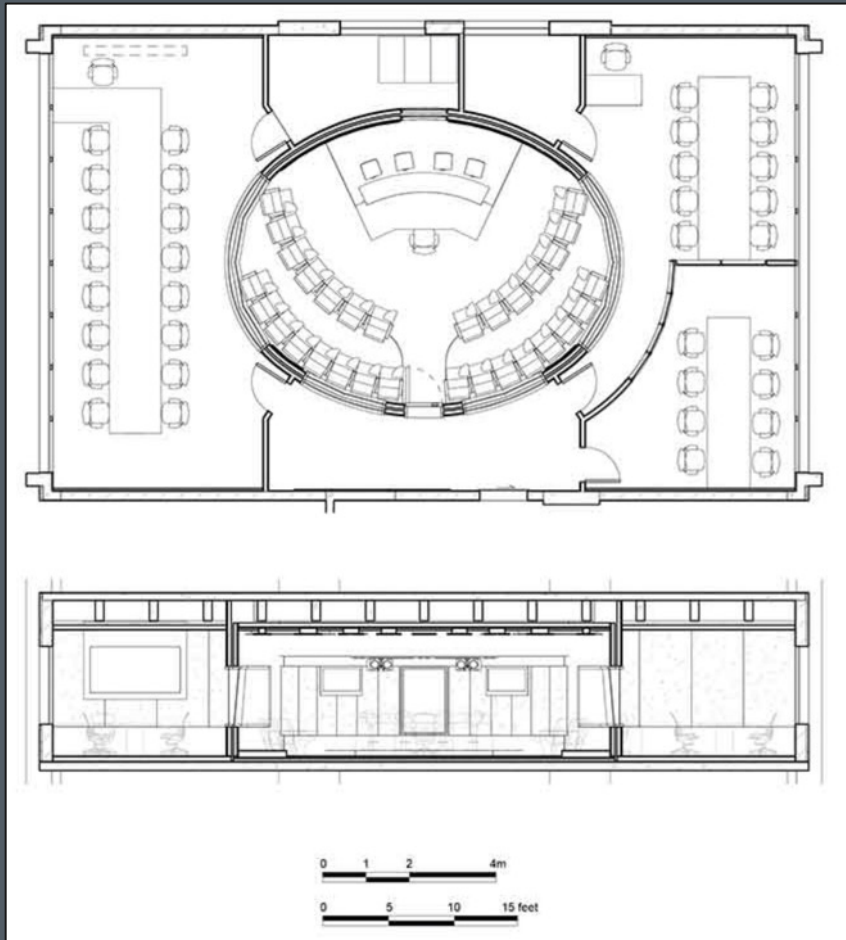



ESPM (Escola Superior de Propaganda e Marketing) São Paulo, Brasil



Radio/Podcast/Classroom



SFR RADIO STATION

Basel, Suíça

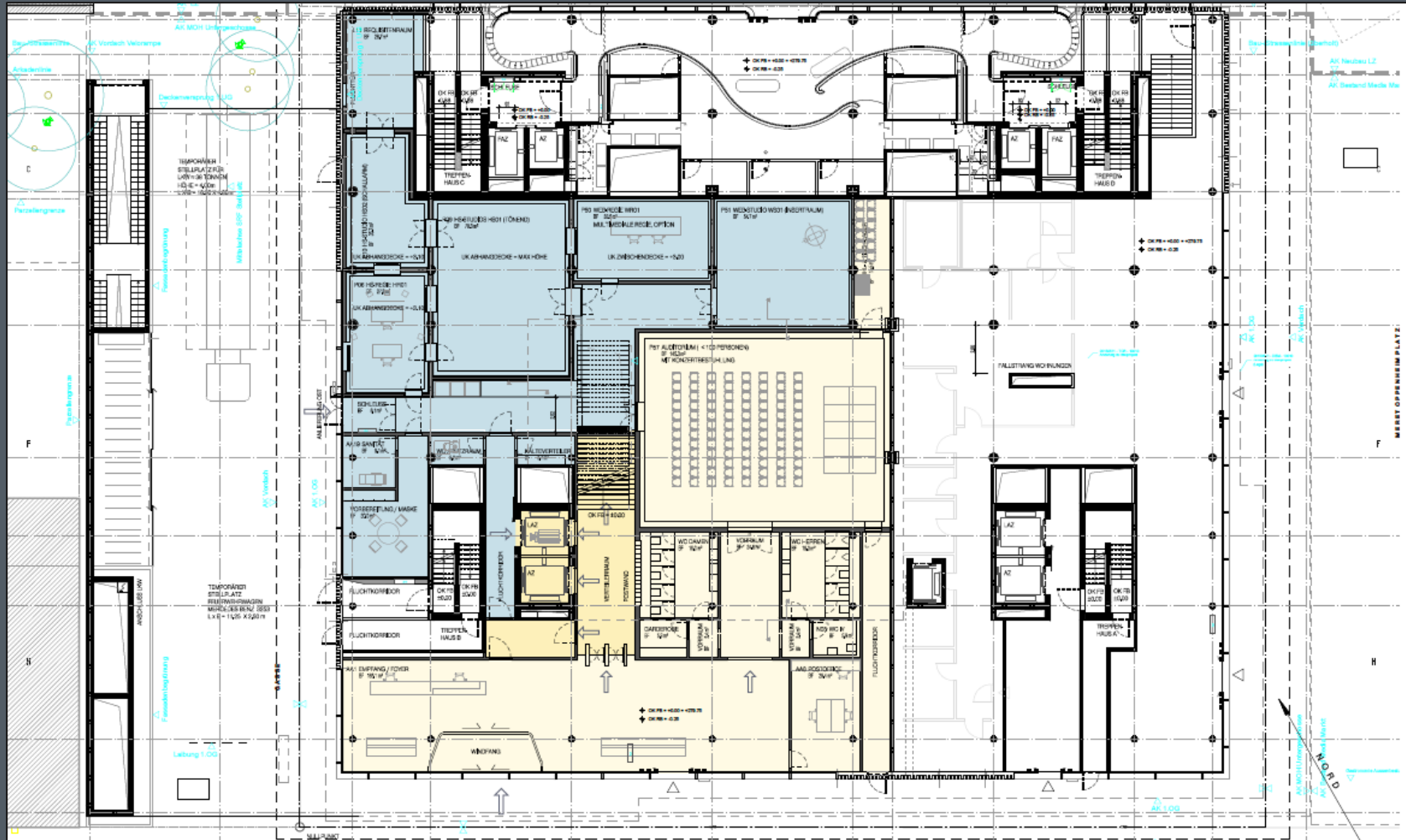



SFR RADIO STATION

Basel, Suíça



Podcast



Edit Room



RADIO MIX FM

São Paulo, Brasil

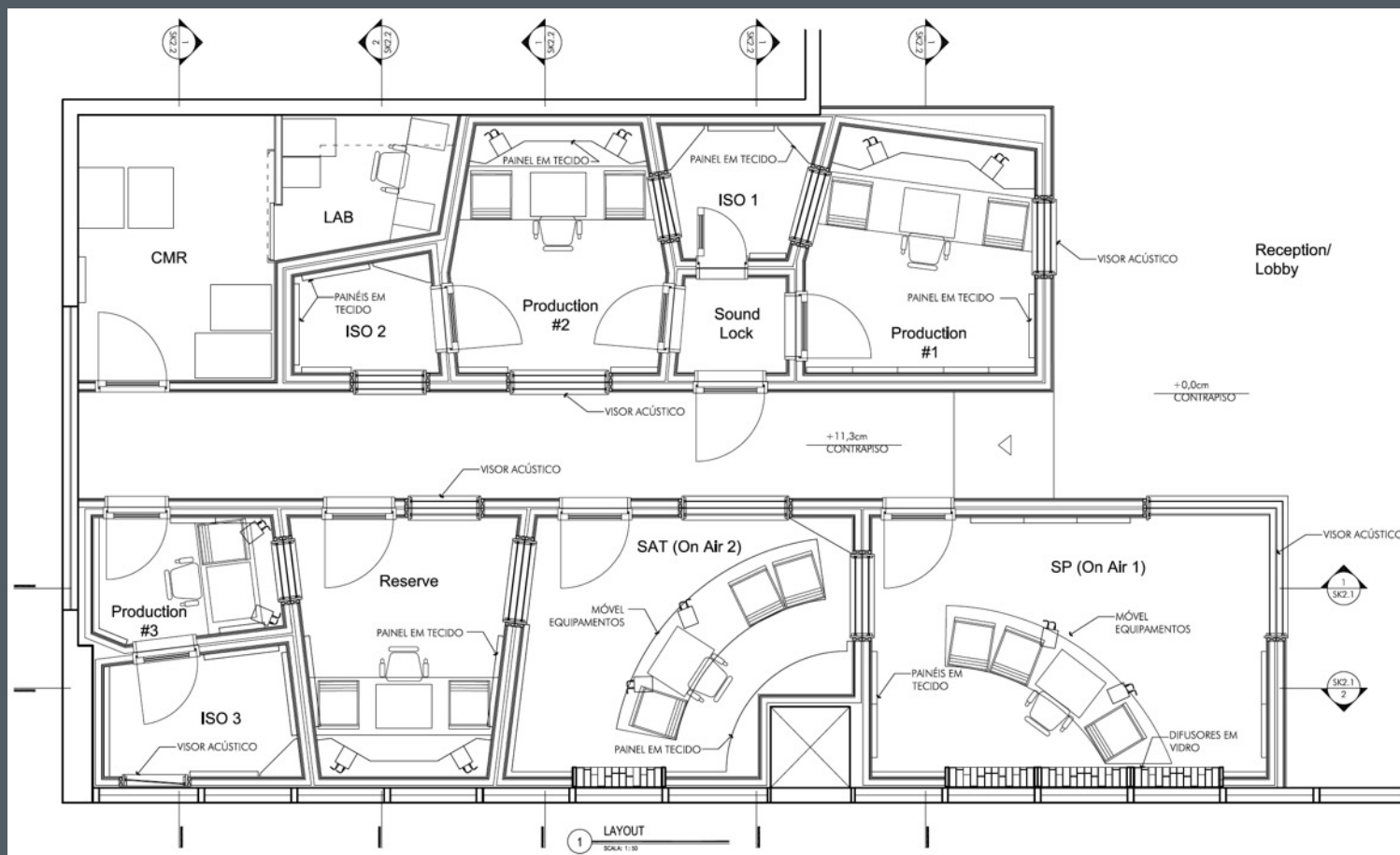



RADIO MIX FM

São Paulo, Brasil



Control 1



Control 2



RADIO MIX FM

São Paulo, Brasil



Estúdios de Produção



RICARDO BACELAR

Fortaleza, Brasil

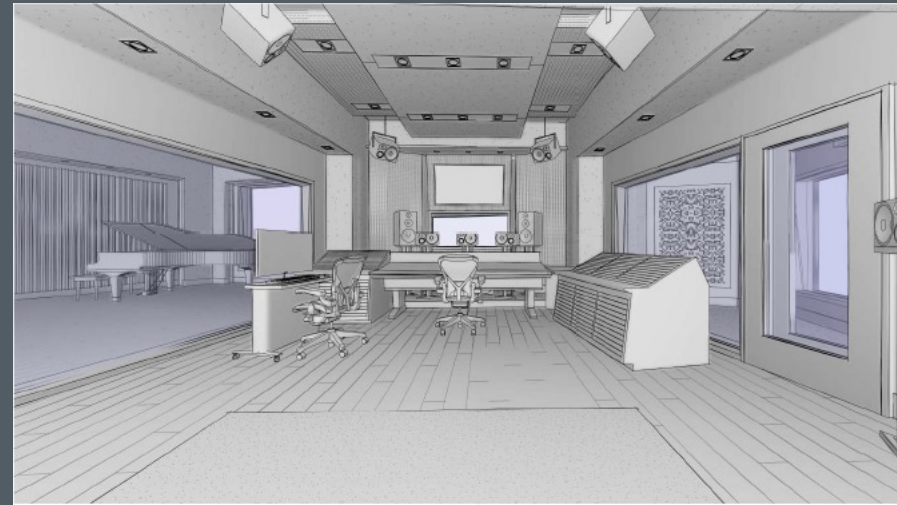
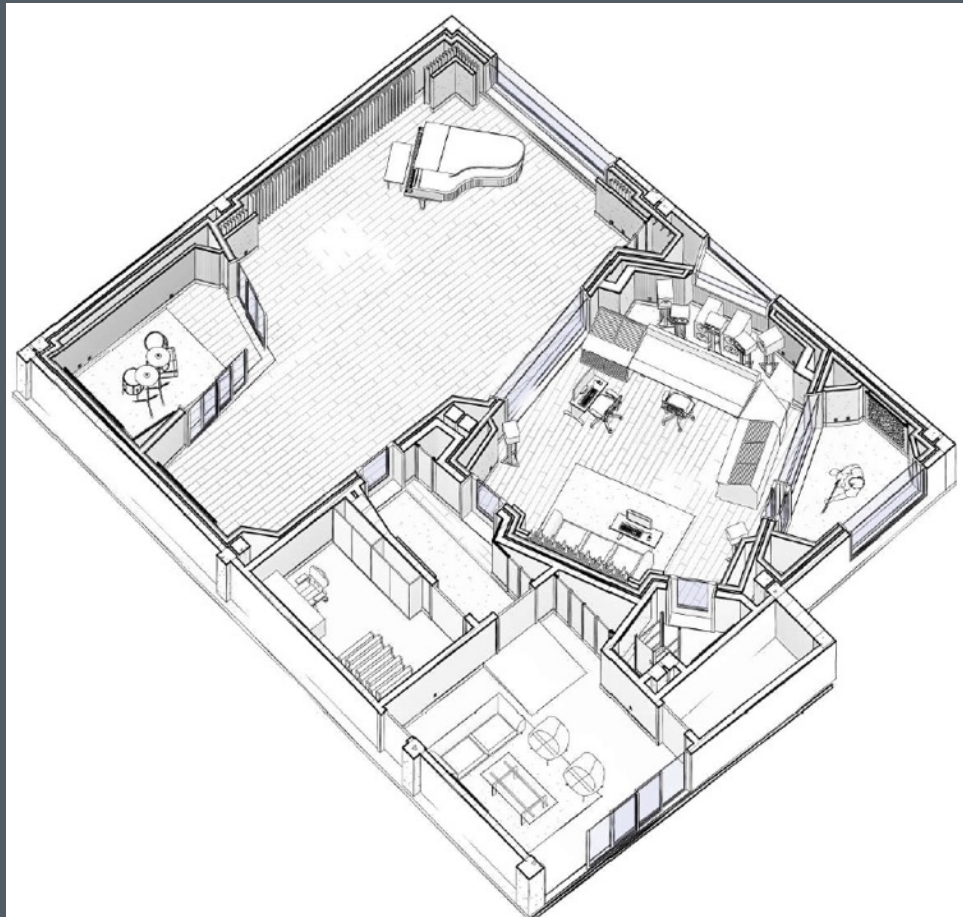



RICARDO BACELAR

Fortaleza, Brasil



Dolby Atmos Control Room



Studio



DIANTE DO TRONO

Belo Horizonte, Brasil

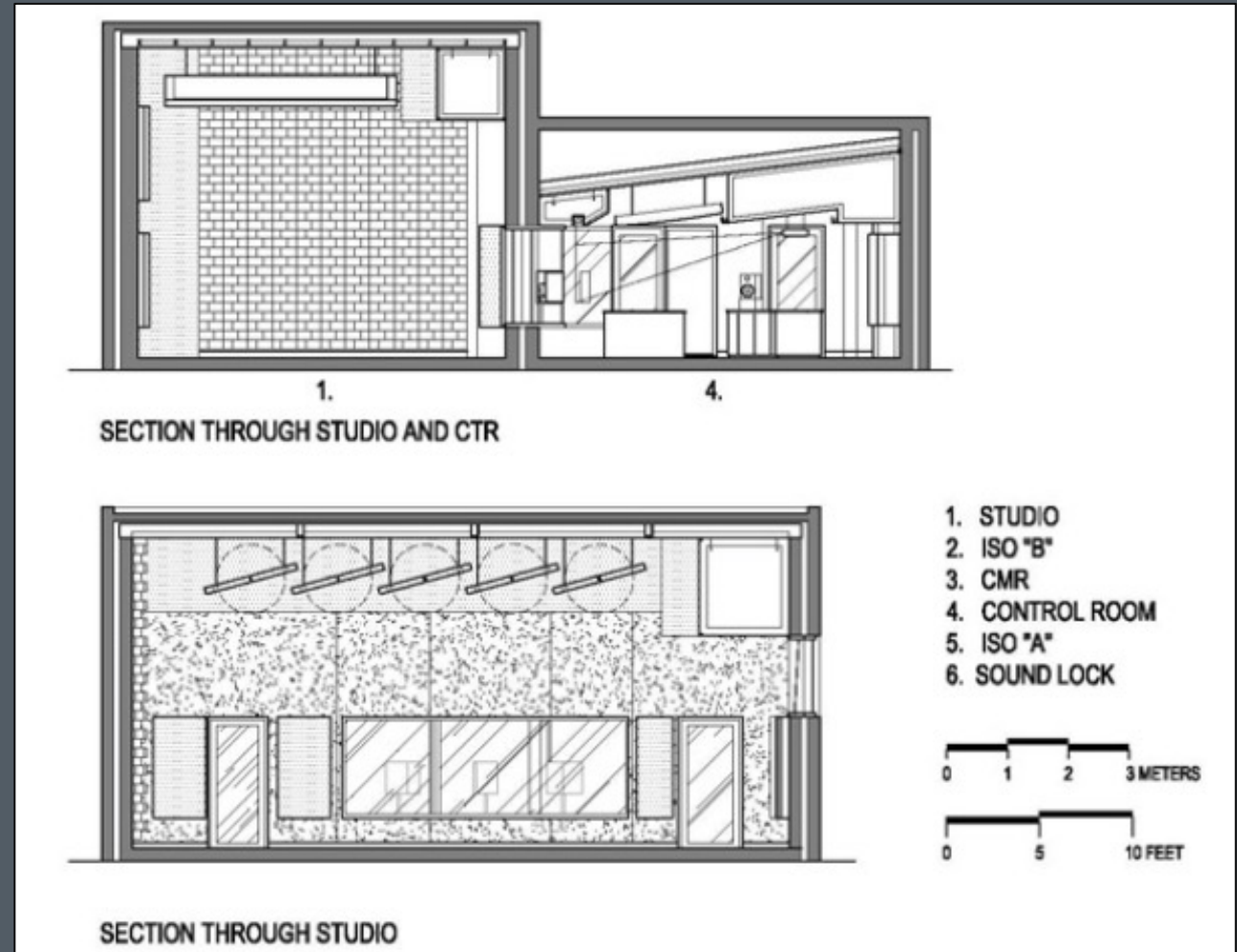
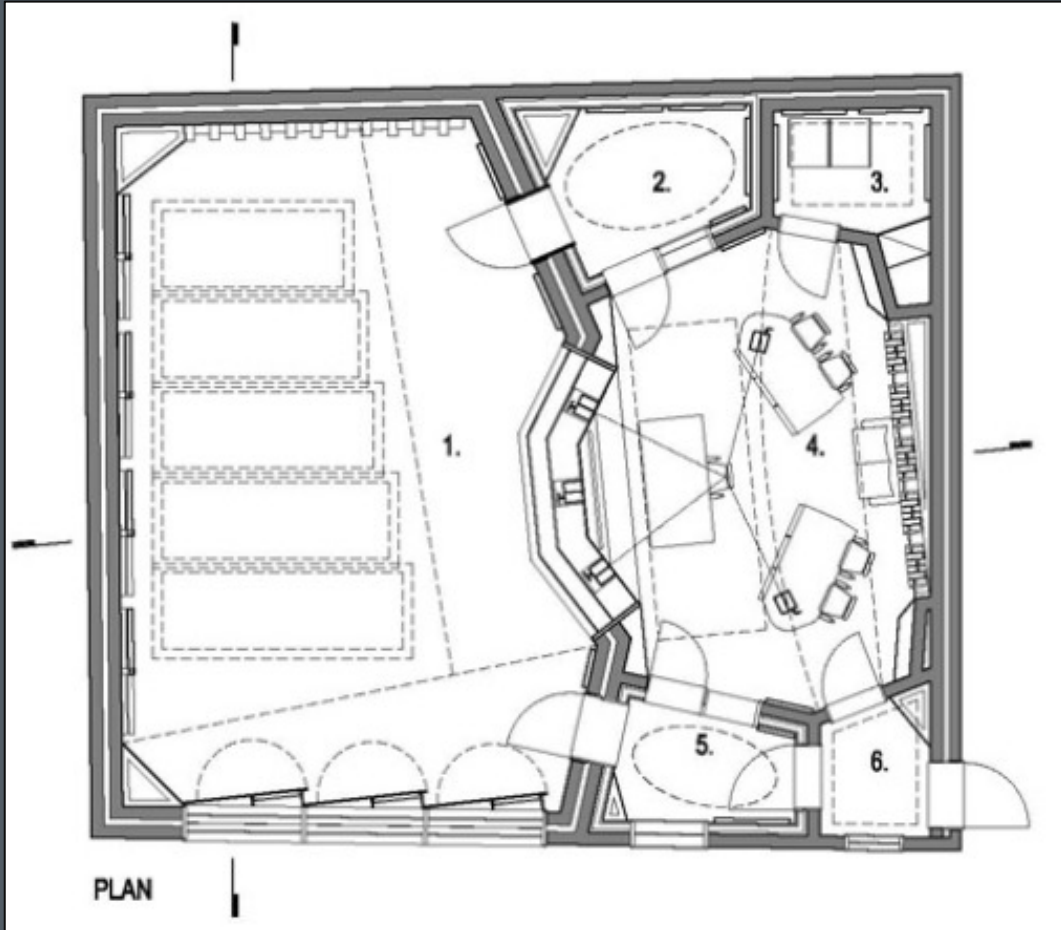



DIANTE DO TRONO

Belo Horizonte, Brasil



Control Room



Studio



STUDIO 21A

Beijin, China

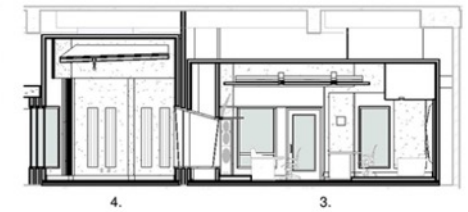
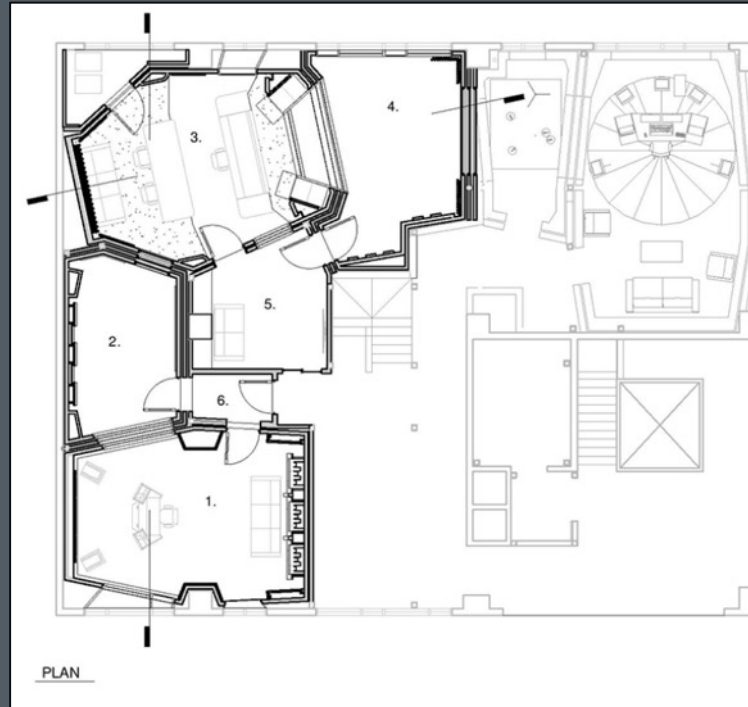
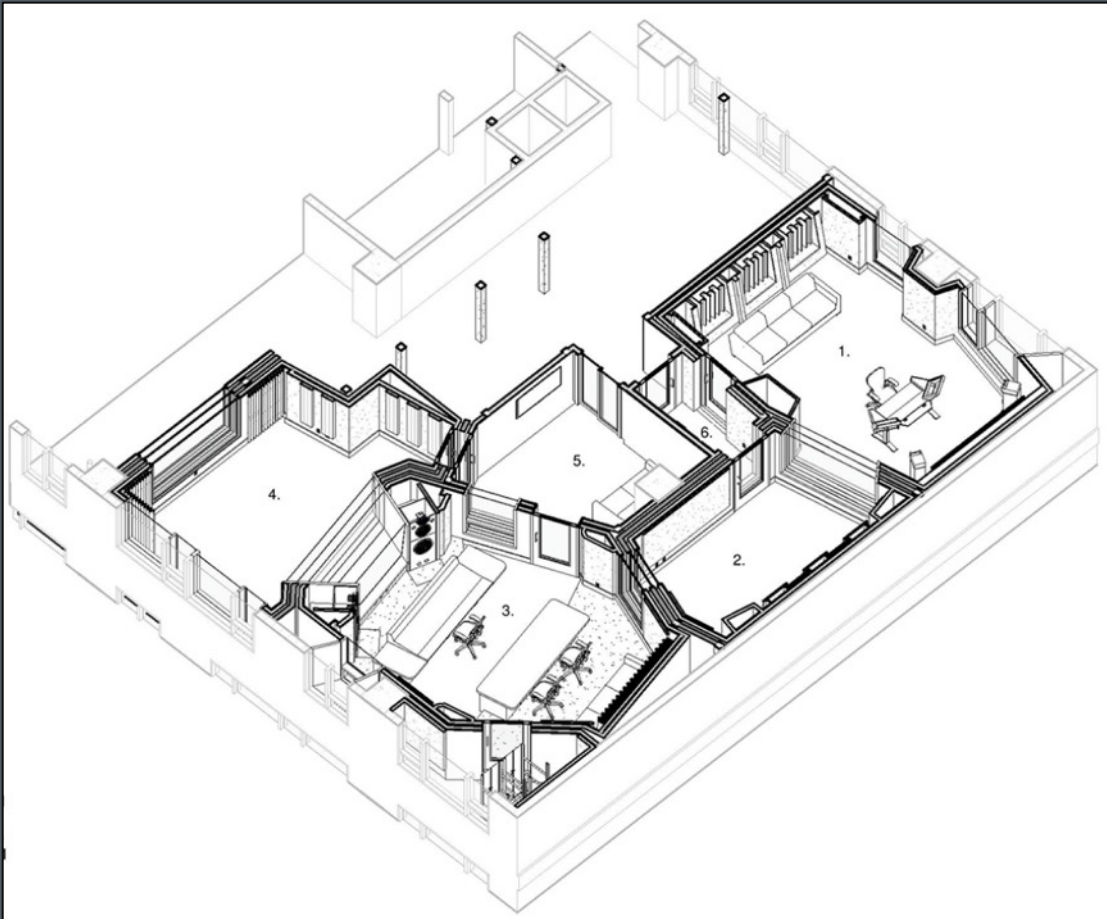

SECTION 1



SECTION 2



STUDIO 21A

Beijin, China



Control Room



Studio



STUDIO 21A

Beijin, China



Control Room 2



ISO Booth



STUDIO 21A

Beijin, China



Studio 2



ISO Booth



NDVK (New Doors, Vintage Keys) Belo Horizonte, Brasil

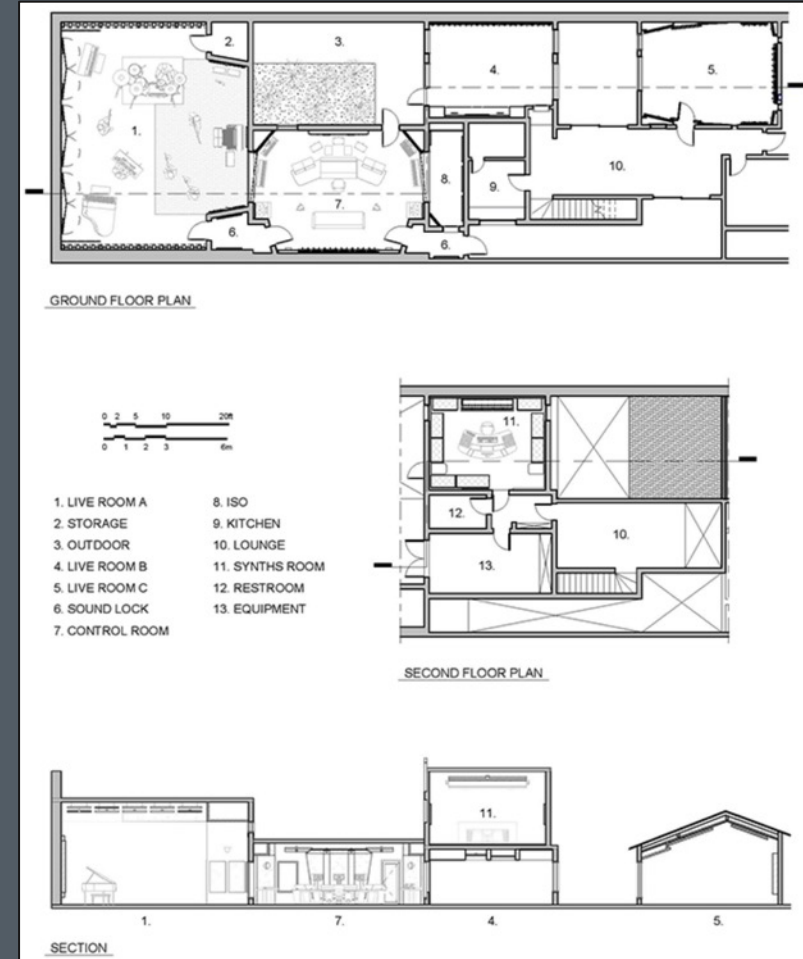
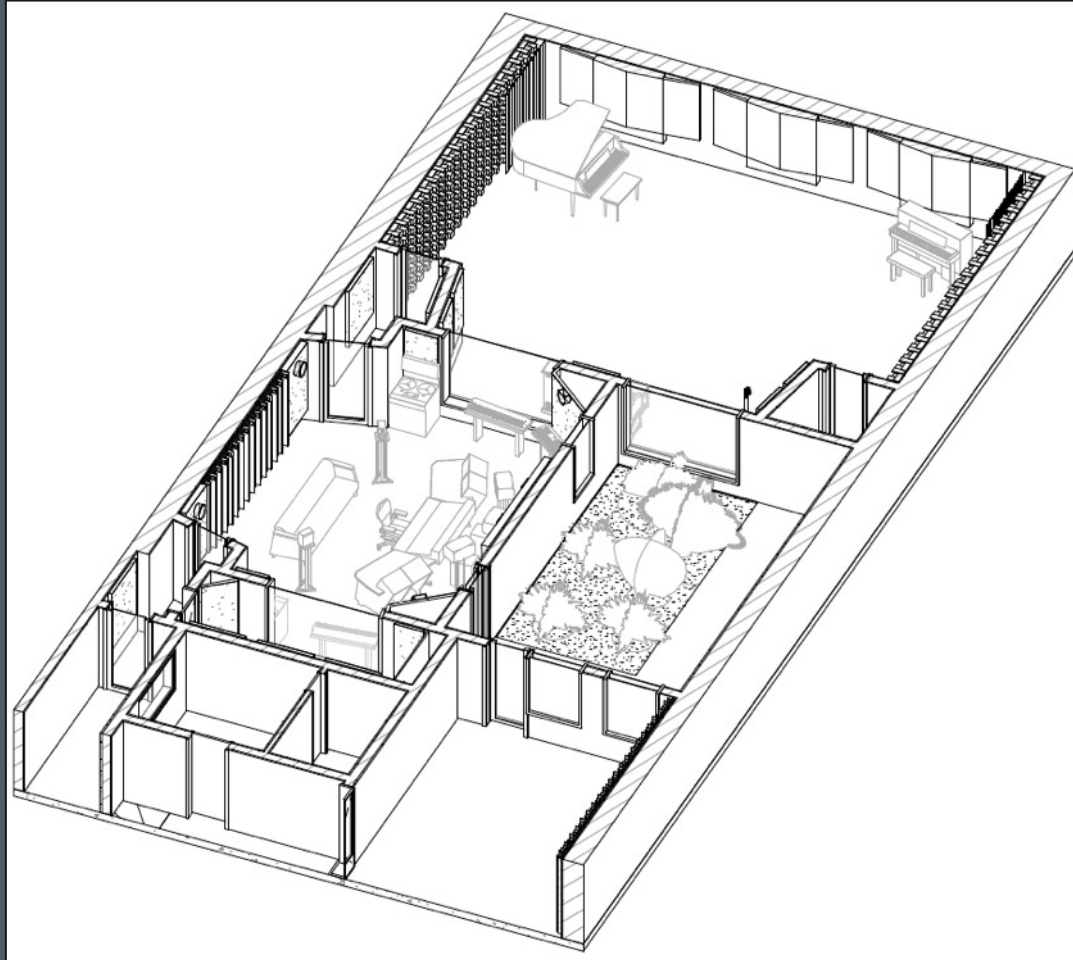



NDVK (New Doors, Vintage Keys) Belo Horizonte, Brasil



Control Room



Studio



NDVK (New Doors, Vintage Keys) Belo Horizonte, Brasil



Synth Room



Studio



FAL - FUTURE ARTS LAB

Vienna, Austria

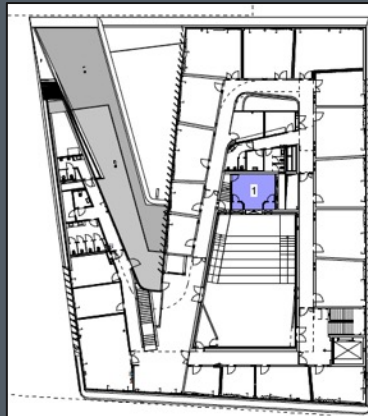

① Niveau +20 OG
1:300



② Niveau +10 OG
1:300

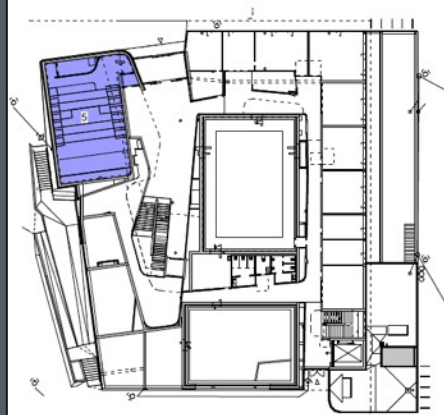

③ Niveau +00 EG
1:300



④ Niveau -10 UG
1:300

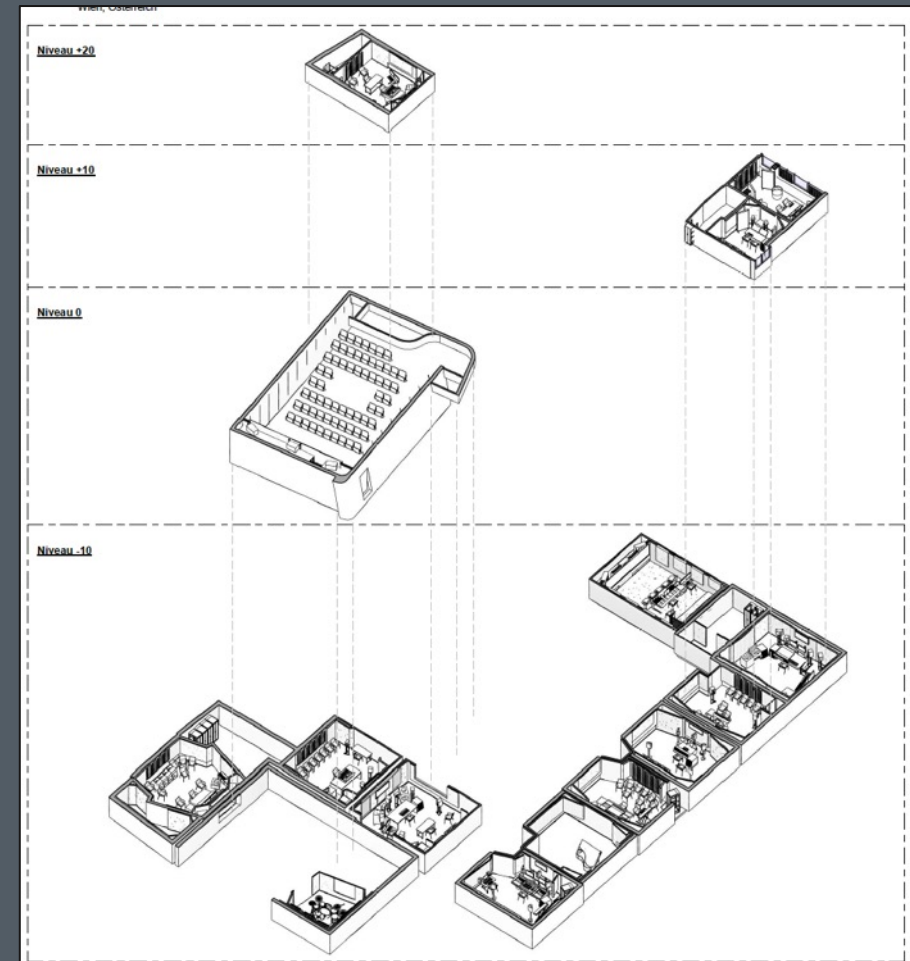



FAL - FUTURE ARTS LAB

Vienna, Austria



Experimental Immersive Audio Studio



FAL - FUTURE ARTS LAB

Vienna, Austria



Dolby Atmos Mixing Room



Sala de Equipamentos



FAL - FUTURE ARTS LAB

Vienna, Austria



Dolby Atmos Mixing Theater



JOTA QUEST

Belo Horizonte, Brasil

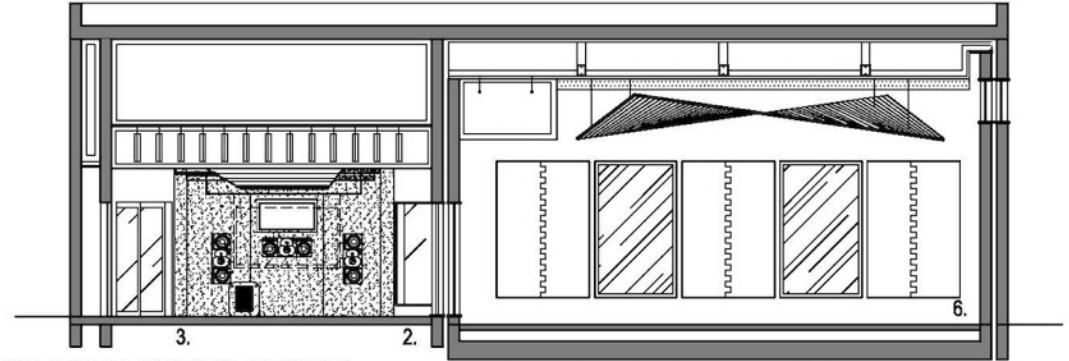
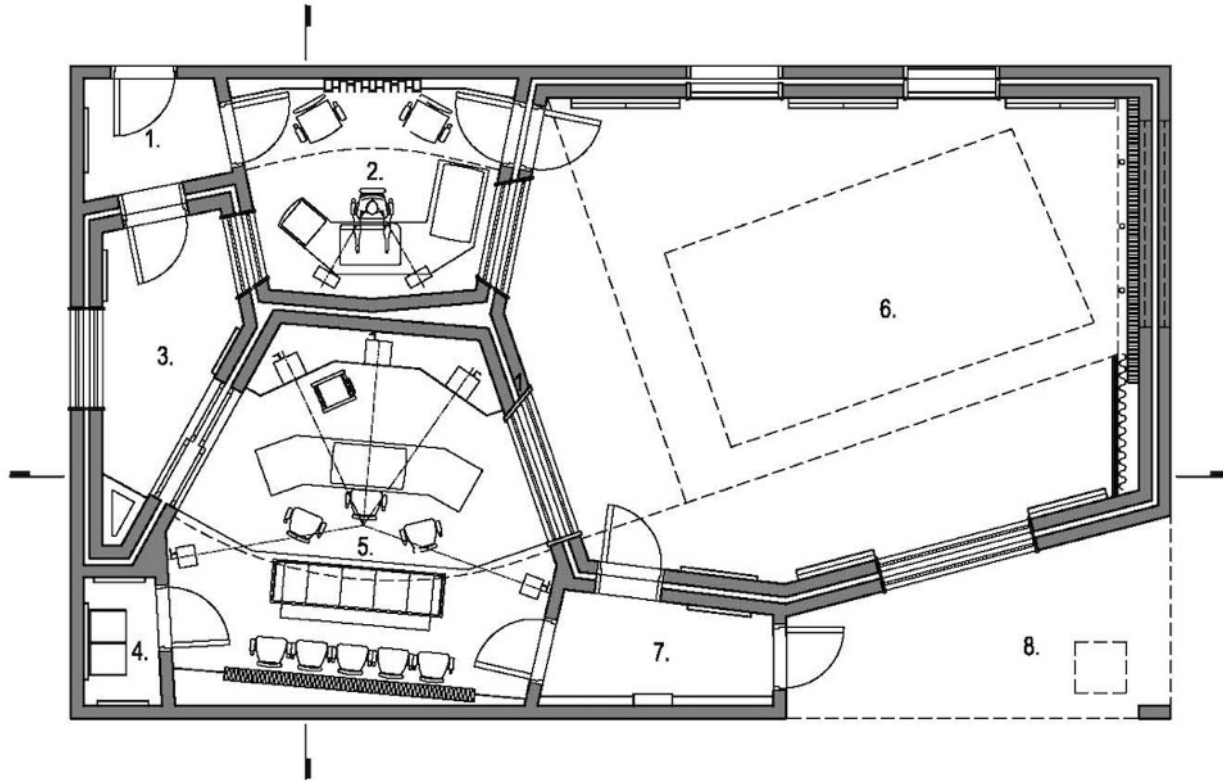

SECTION THROUGH ISO CTR "B" AND STUDIO

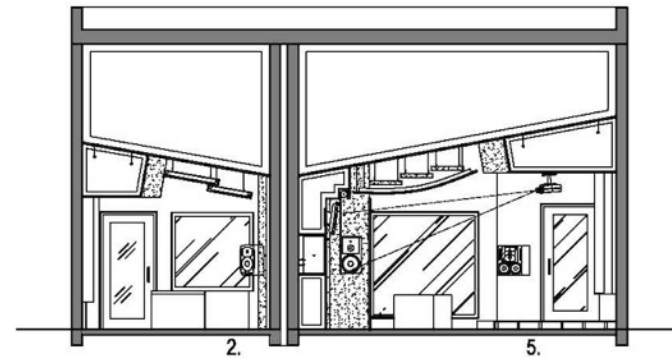

SECTION THROUGH CTR "B" AND "A"

- 1. SOUND LOCK "B"
- 2. CONTROL ROOM "B"
- 3. ISO
- 4. CONTROL ROOM "A"
- 5. ISO "A"
- 6. STUDIO
- 7. SOUND LOCK "A"
- 8. ACCESS

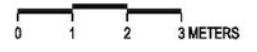



JOTA QUEST

Belo Horizonte, Brasil



Control Room



Studio



NAC STUDIOS

Chennai, India



Dolby Atmos Mixing Theater



NAC STUDIOS

Chennai, India



Dolby Atmos Mixing Theater



Control Room



STUDIO 13

Mexico, DF

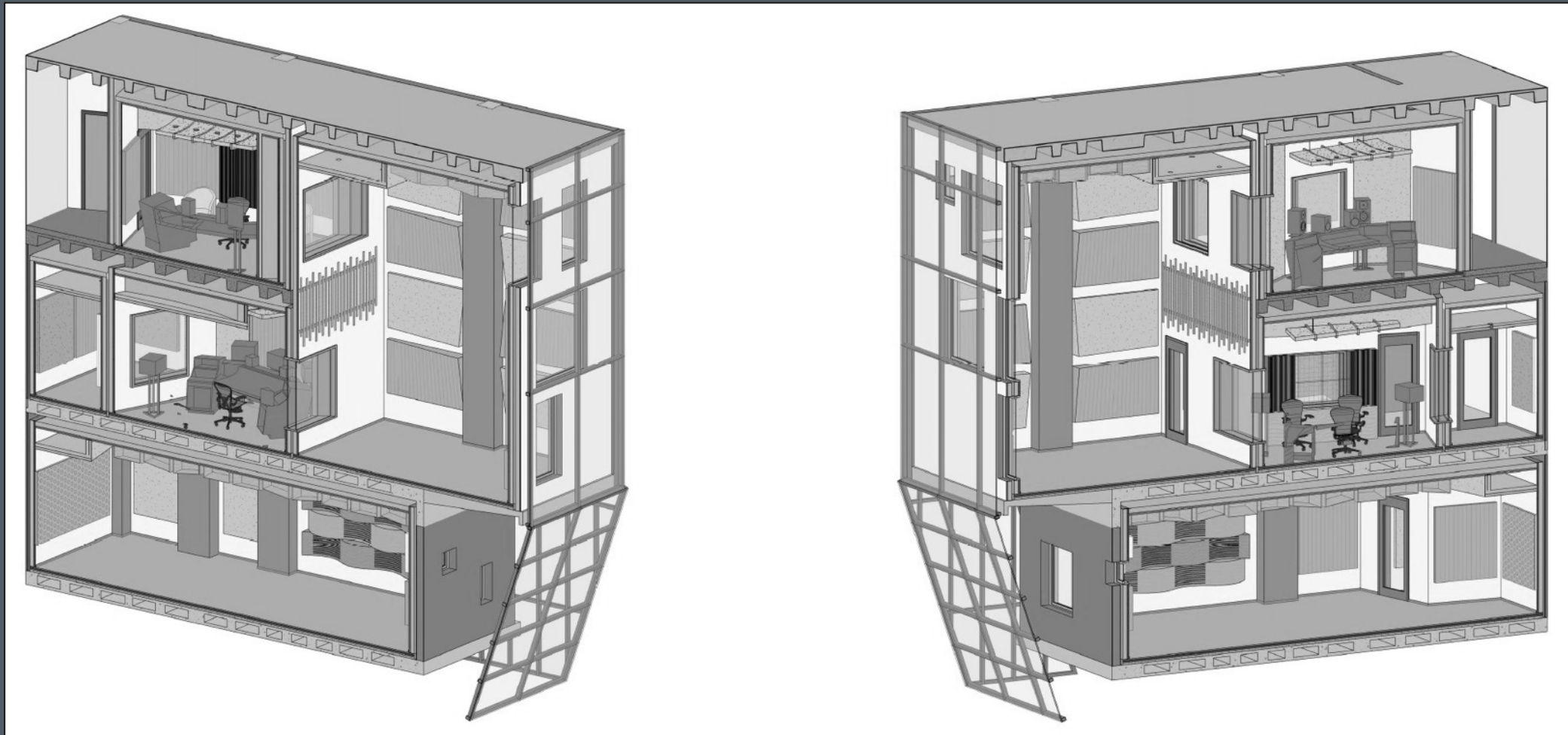



STUDIO 13

Mexico, DF



Control Room



Studio



VIENNA CITY SOUND

Vienna, Austria

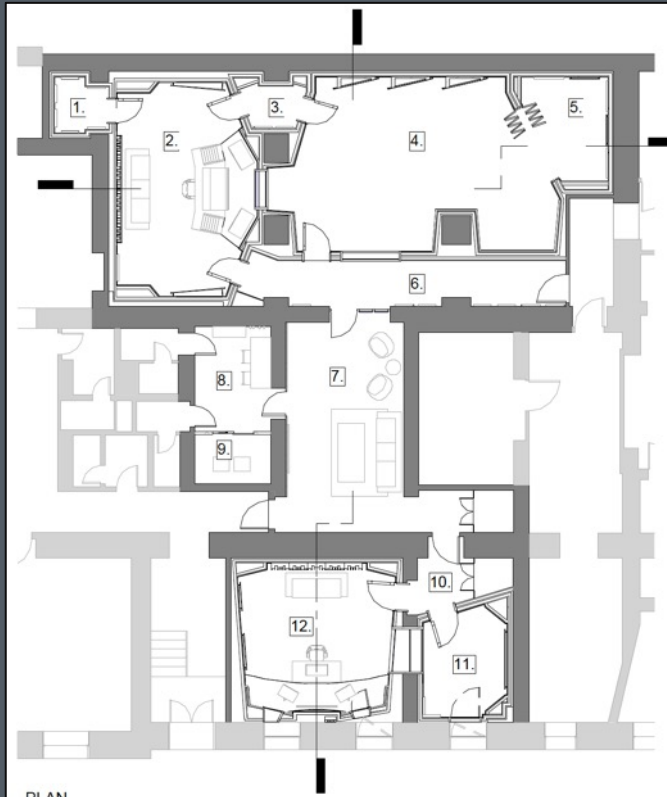
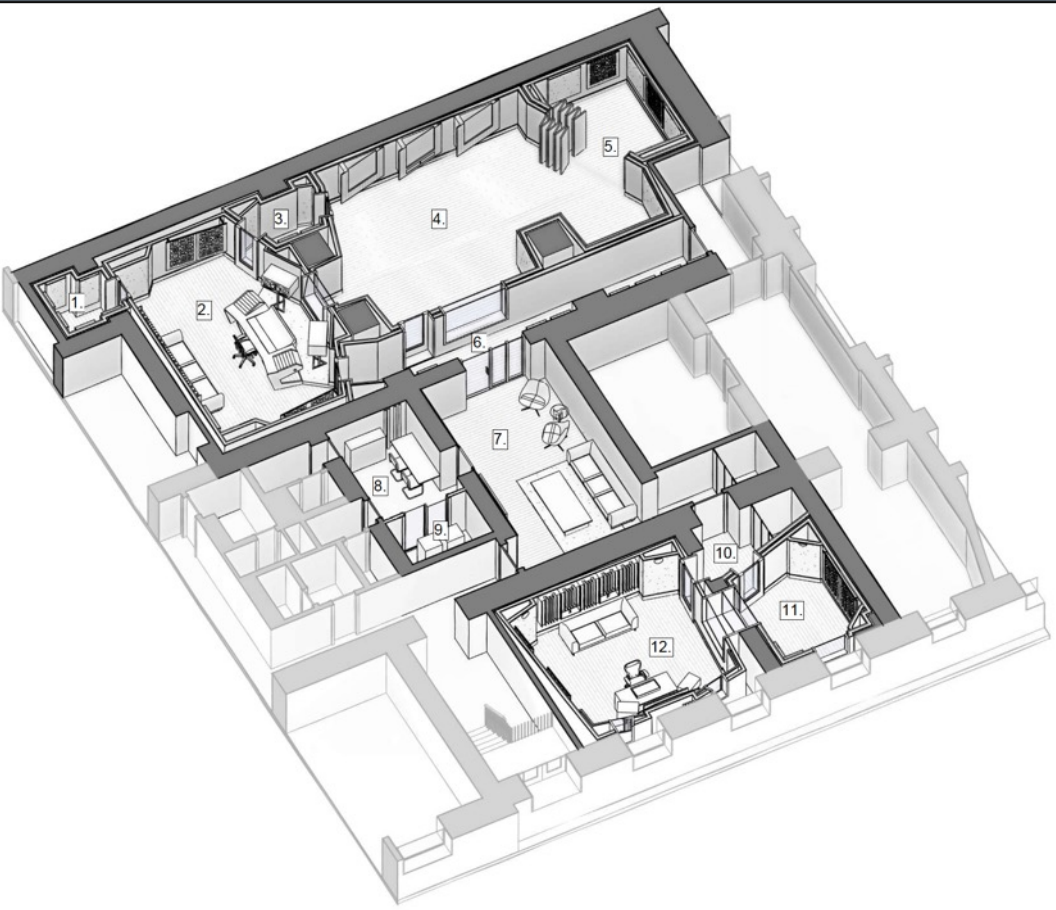

PLAN

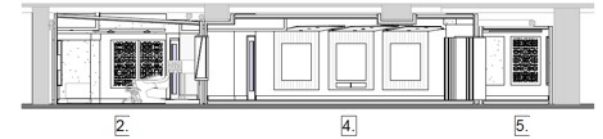

SECTION 1



SECTION 2

- 1. AMP BOOTH
- 2. CONTROL ROOM 1
- 3. S.L. / VOCAL BOOTH
- 4. LIVE 1
- 5. ISO BOOTH
- 6. SOUND LOCK 1
- 7. HALL
- 8. KITCHEN
- 9. CMR
- 10. SOUND LOCK 2
- 11. LIVE 2
- 12. CONTROL ROOM 2

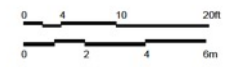



VIENNA CITY SOUND

Vienna, Austria



Control Room



Studio



PD STUDIOS Saudi Arabia

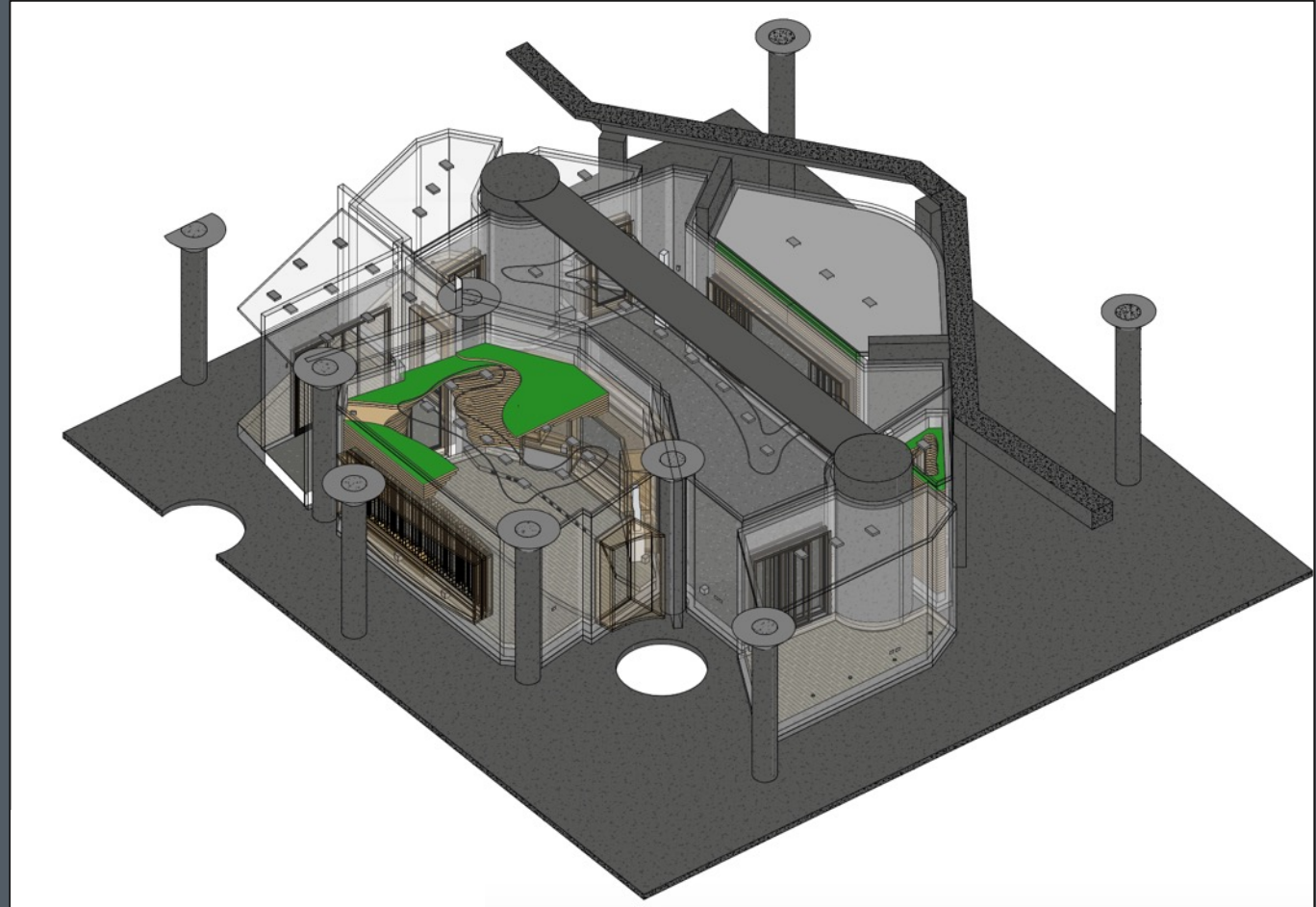
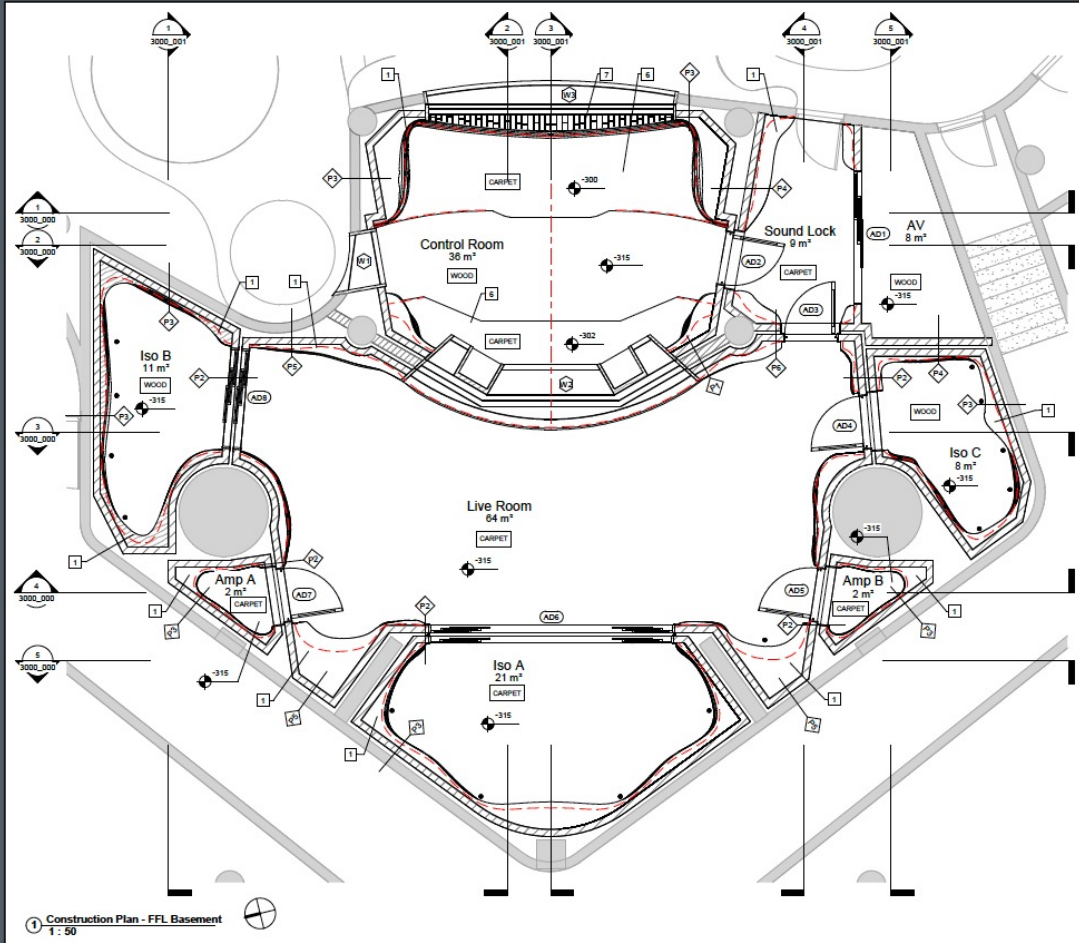



PD STUDIOS

Saudi Arabia



Control Room



Studio



STUDIO 94

Orlando, USA

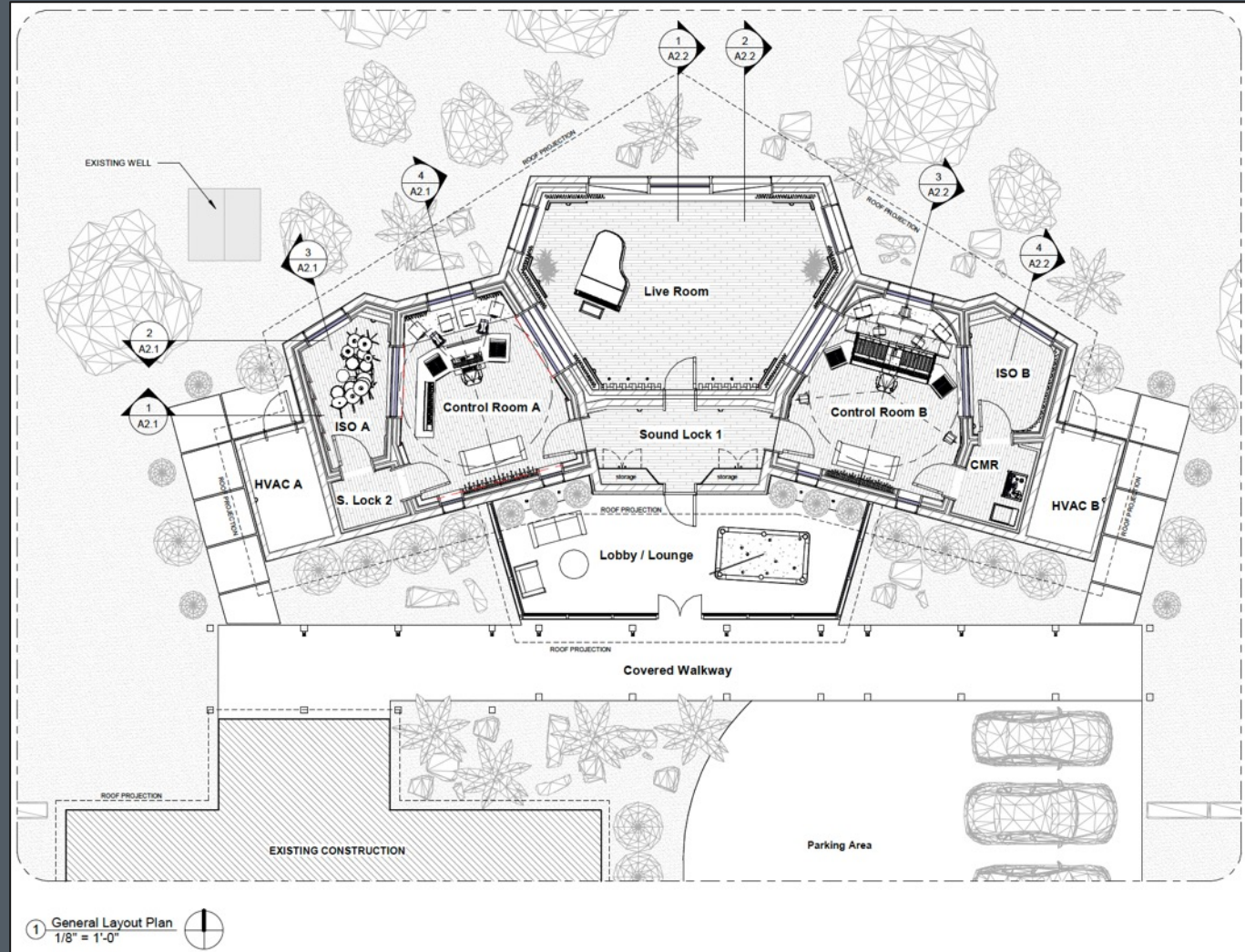



STUDIO 94

Orlando, USA



Control Room



Studio



CUEC UNAM

Mexico, DF

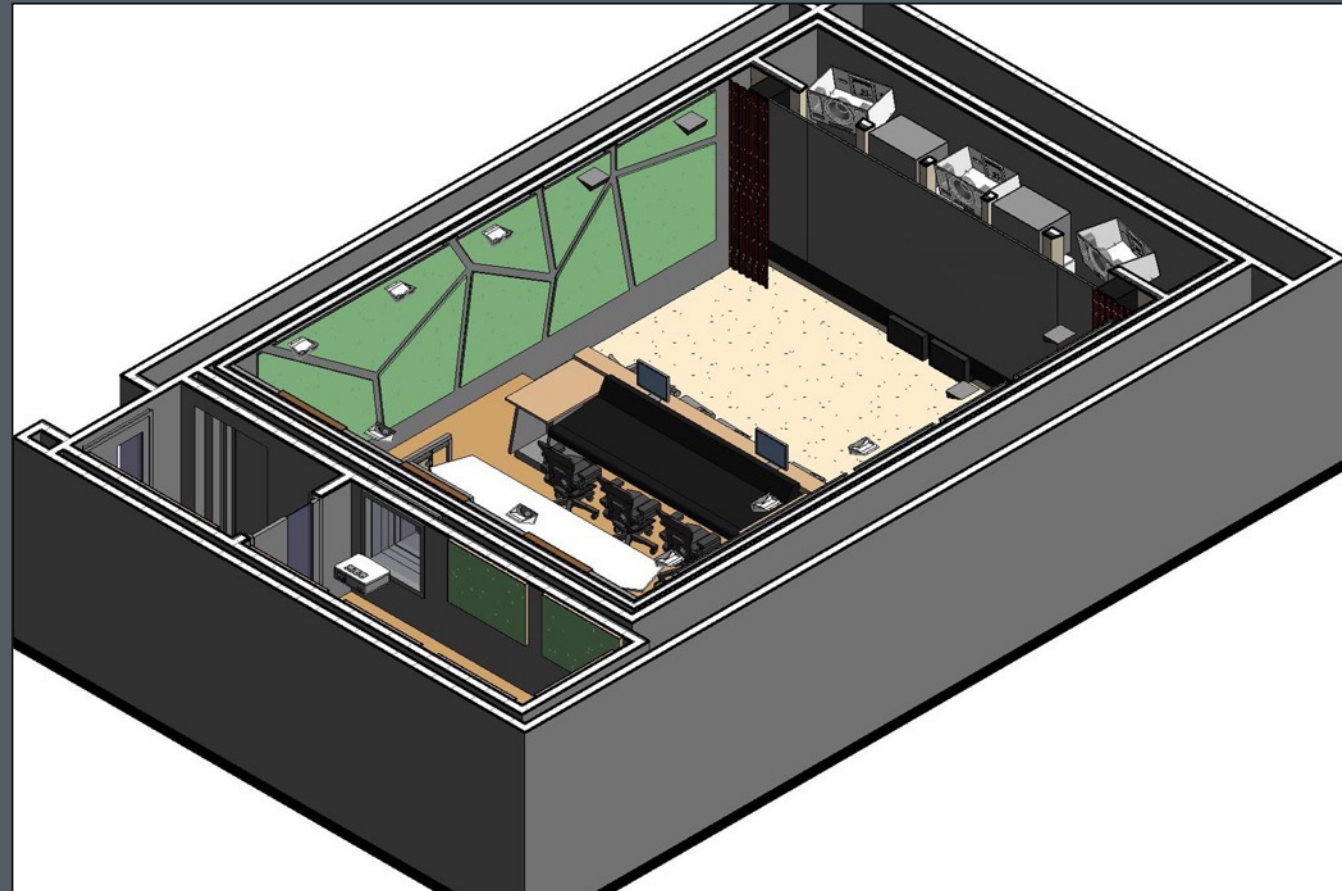
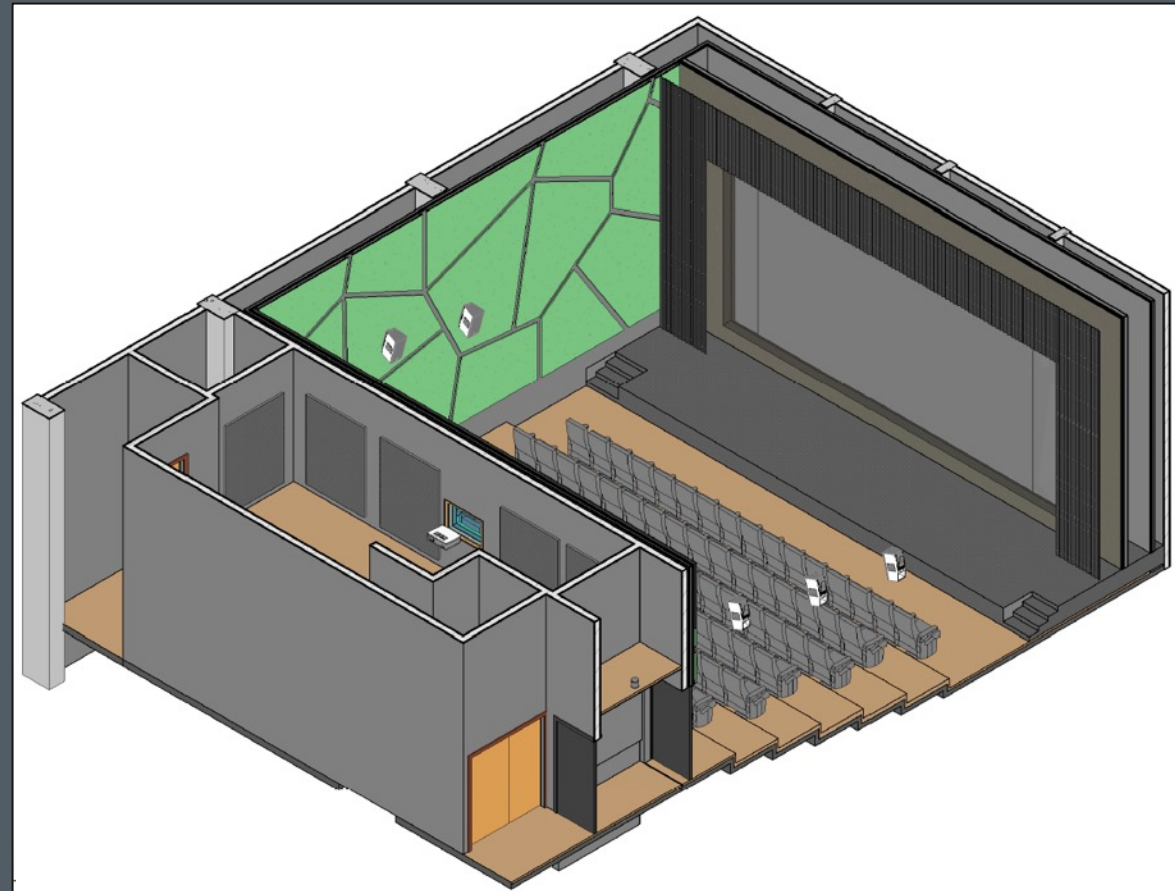



CUEC UNAM

Mexico, DF



Screening Theater



Dolby Atmos Mixing Room



MUSIC ACADEMY

Bern, Suíça

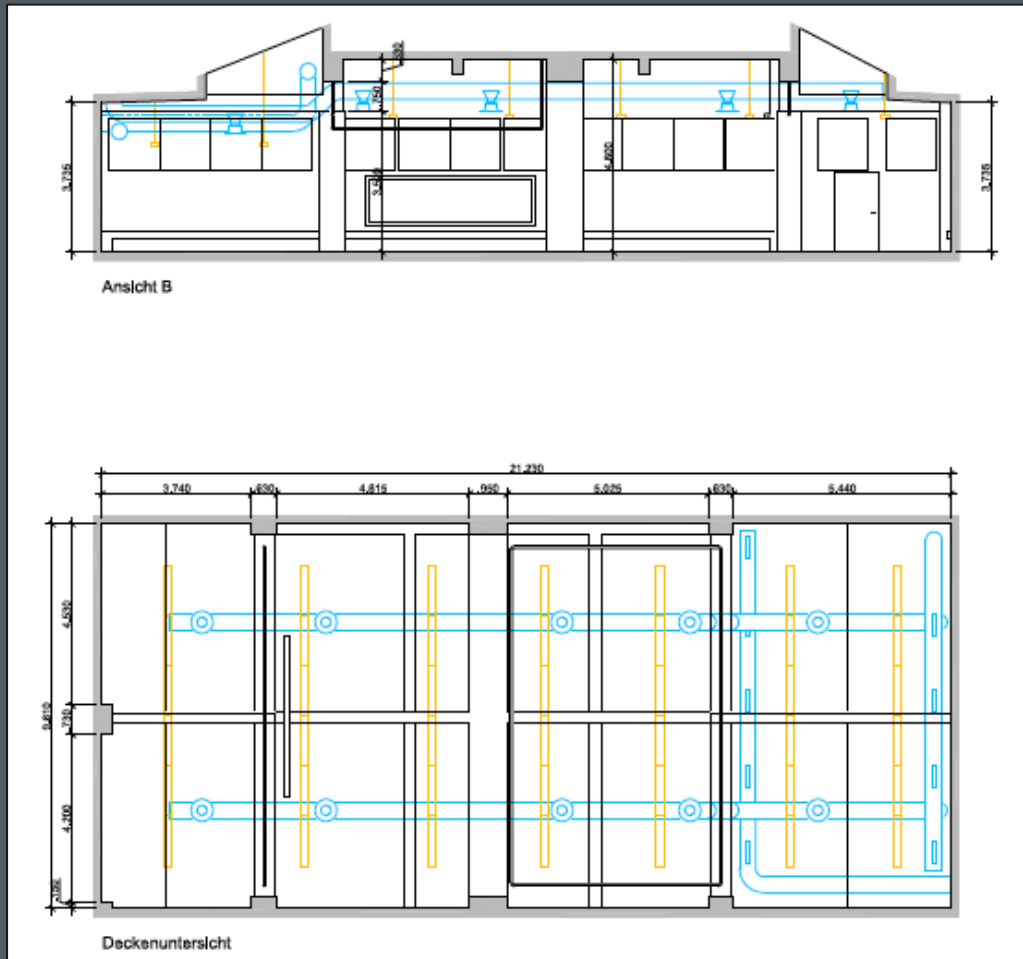



MUSIC ACADEMY

Bern, Suíça



Performance Room



WSDG Europe Basel, Suíça

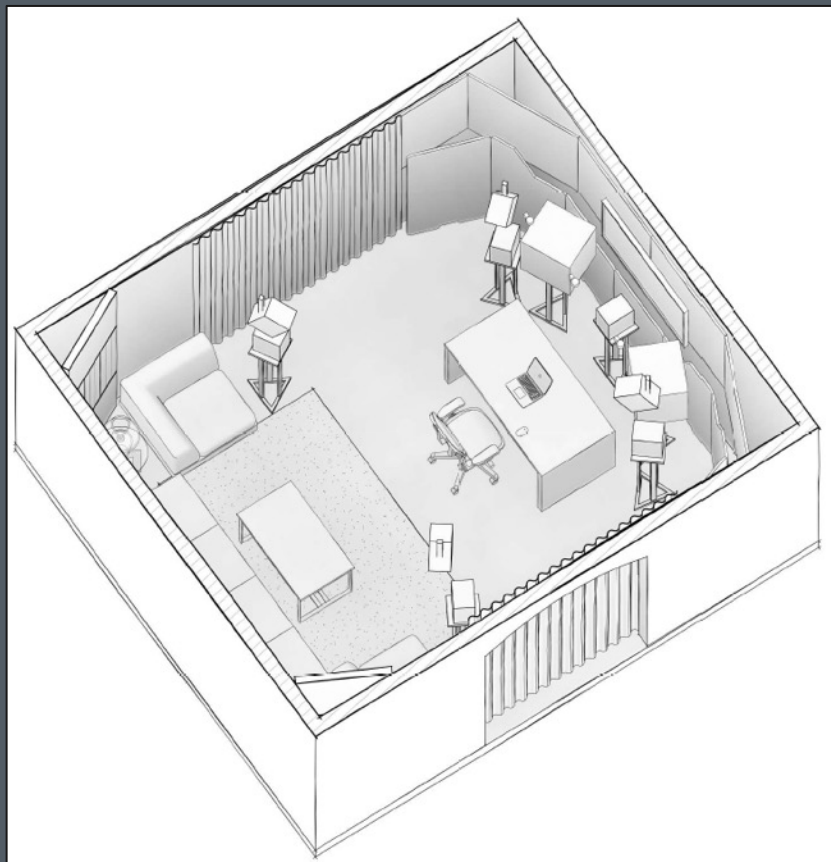



WSDG Europe – ACOUSTIC LAB

Basel, Suíça



Immersive Audio Test Room



CAT DEALERS

Rio de Janeiro, Brasil

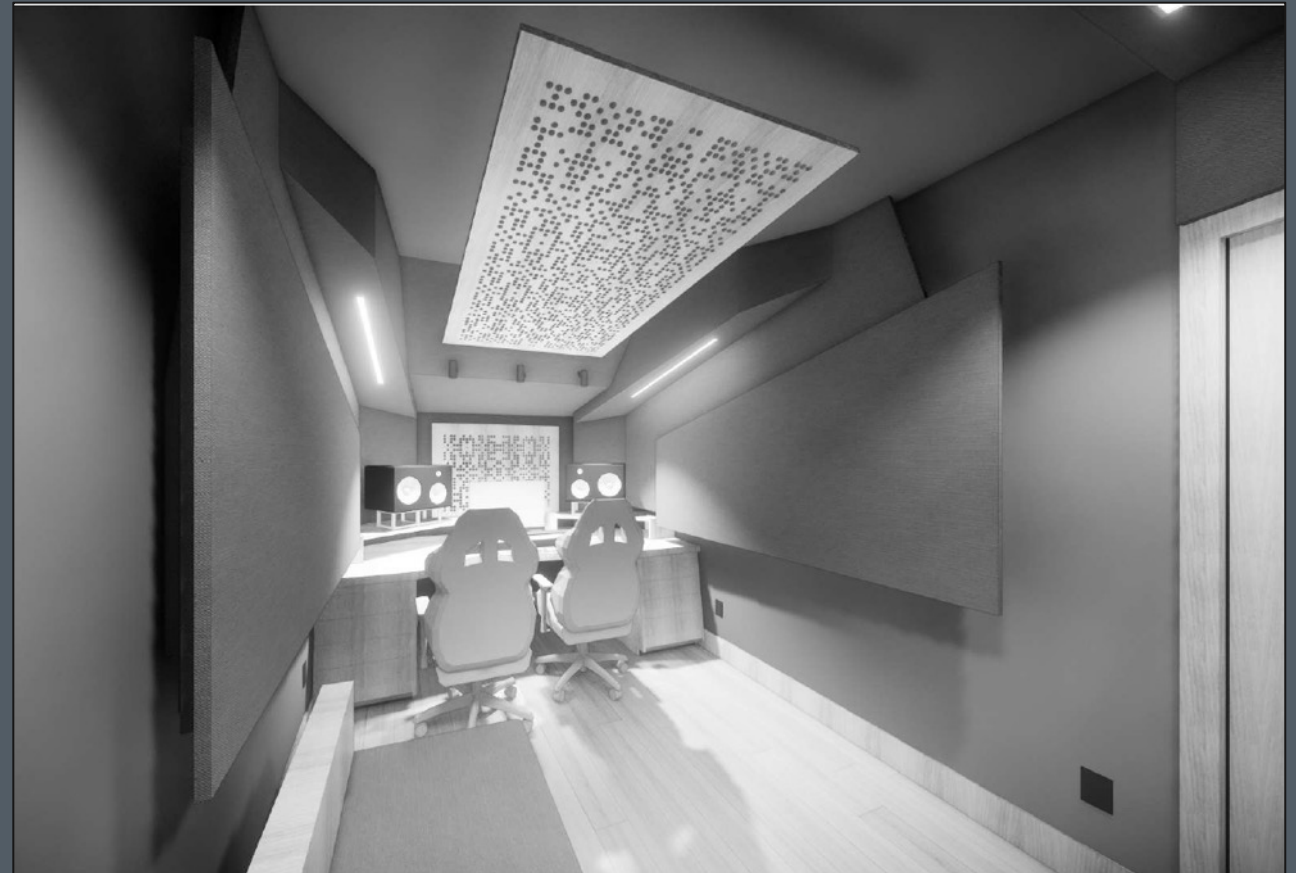
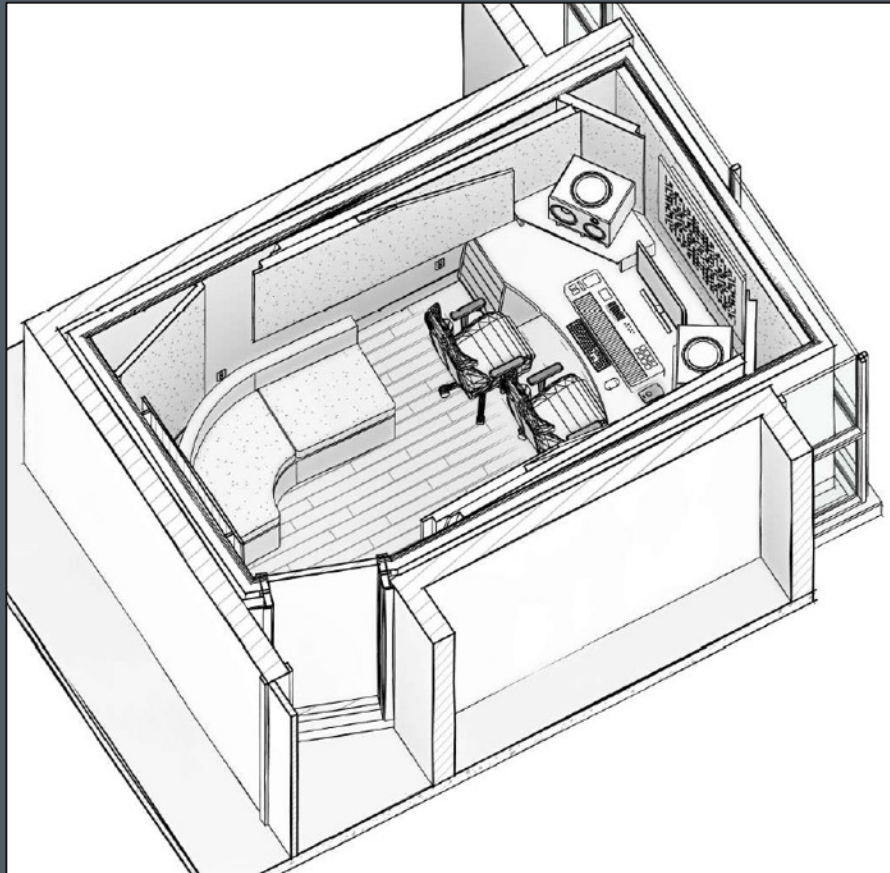



WSDG Europe – ACOUSTIC LAB

Basel, Suíça



Mixing Room





FÁBRICA DE CULTURA DE DIADEMA

São Paulo, Brasil

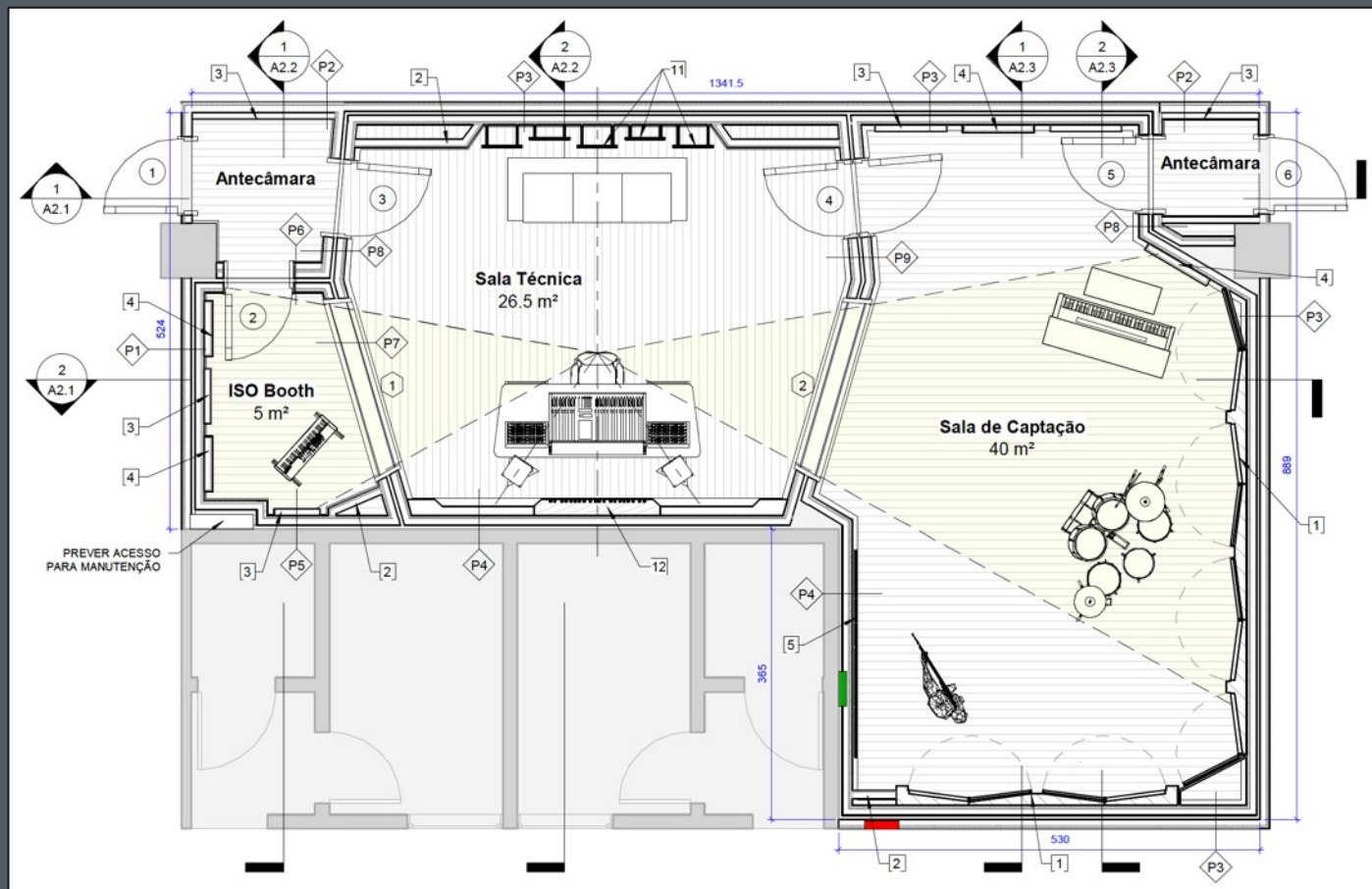
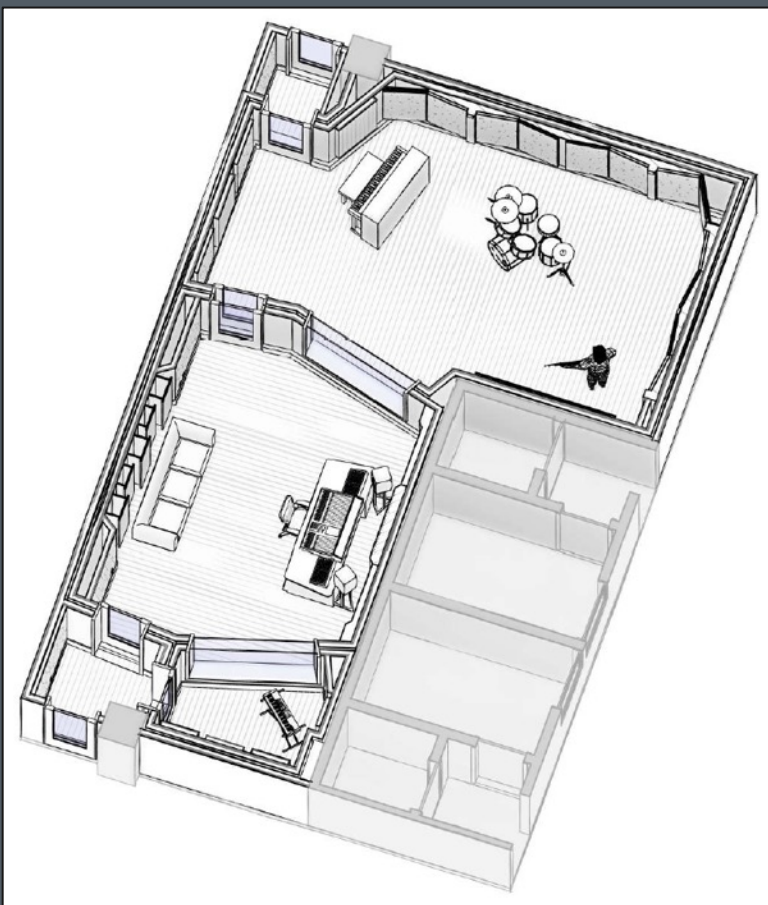



FÁBRICA DE CULTURA DE DIADEMA

São Paulo, Brasil



Control Room



Studio



MIX 2 GO

São Paulo, Brasil

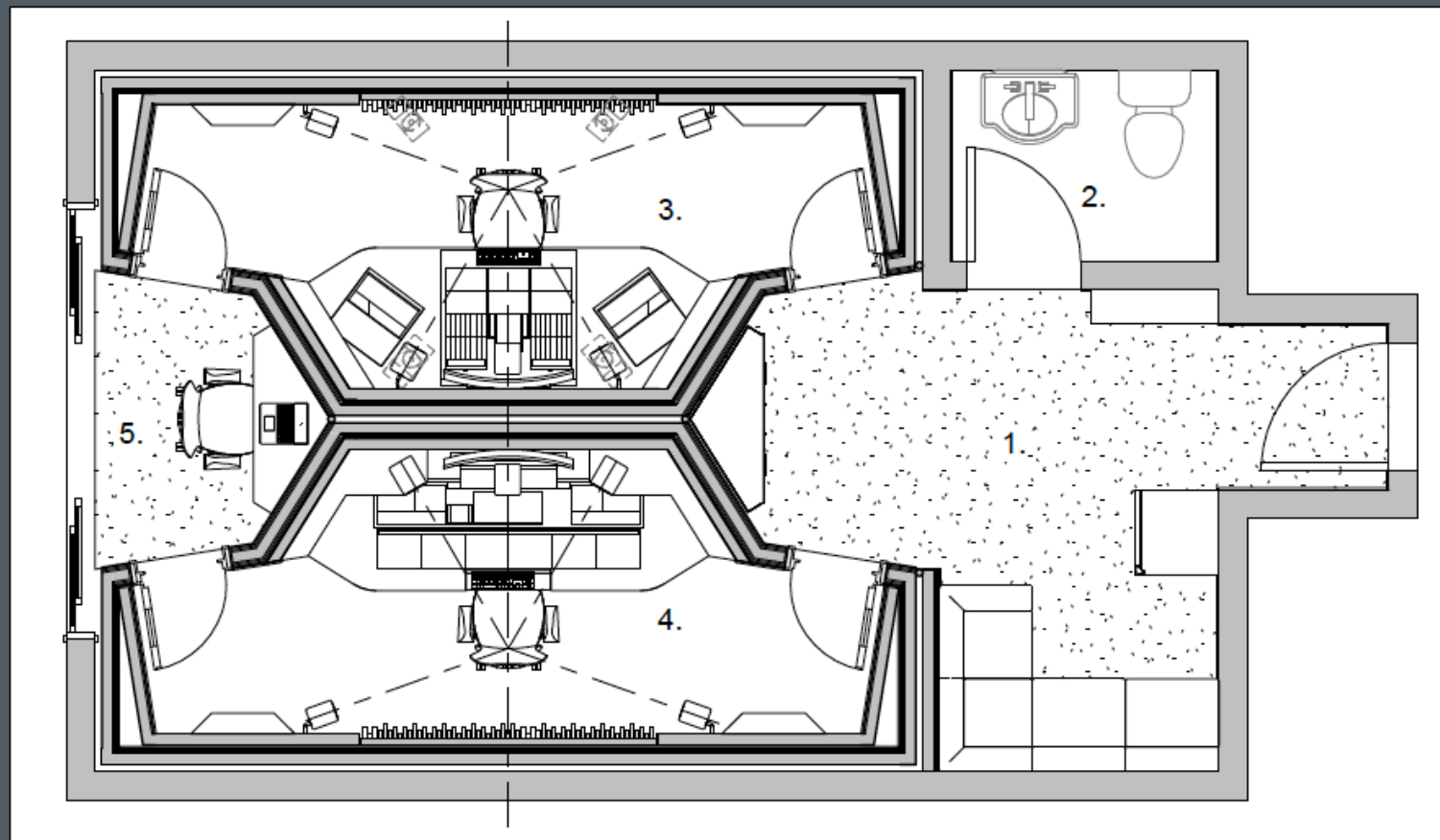
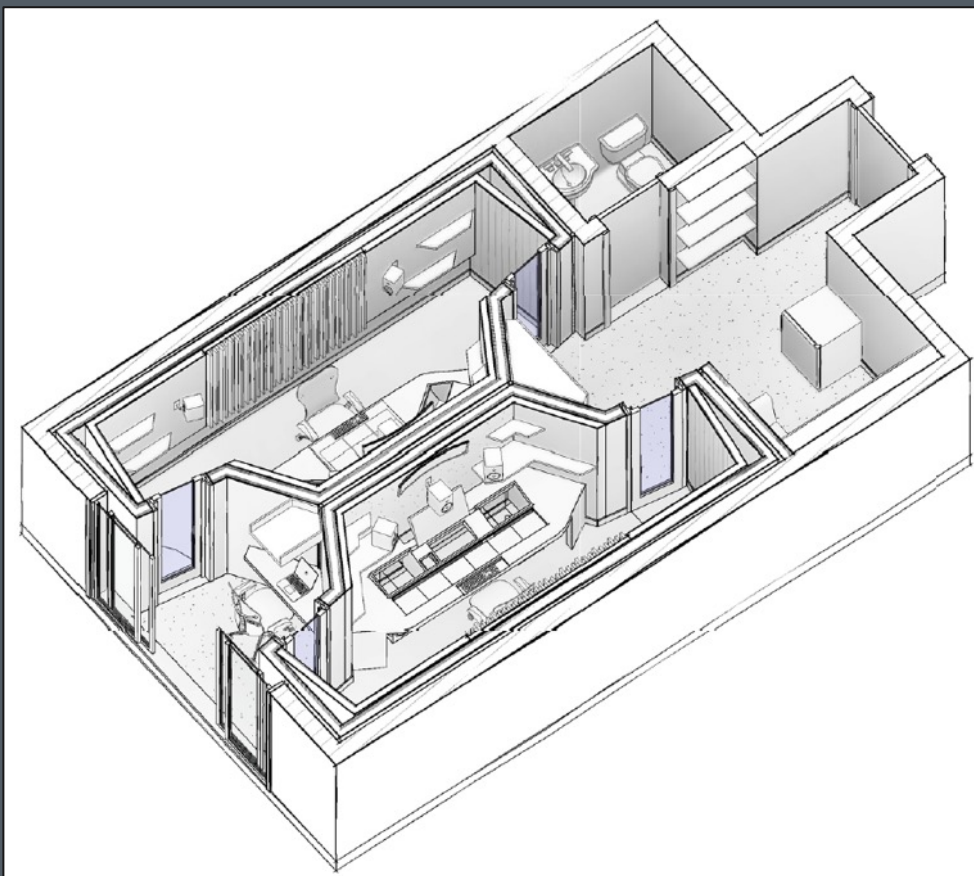



MIX 2 GO

São Paulo, Brasil



Dolby Atmos Mixing Room



Dolby Atmos Mixing Room



LUÃ SANTANA Home Studio

São Paulo, Brasil

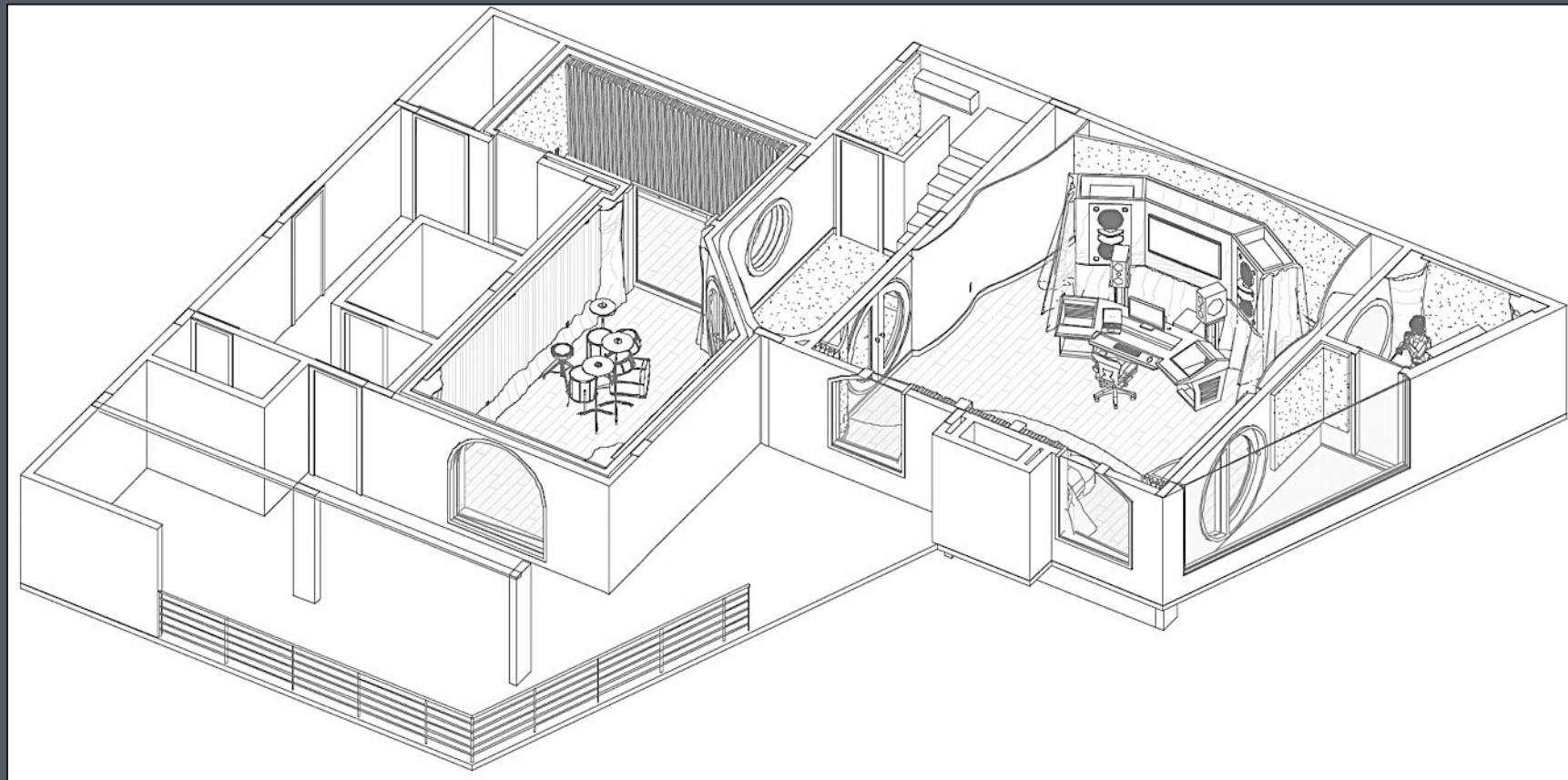
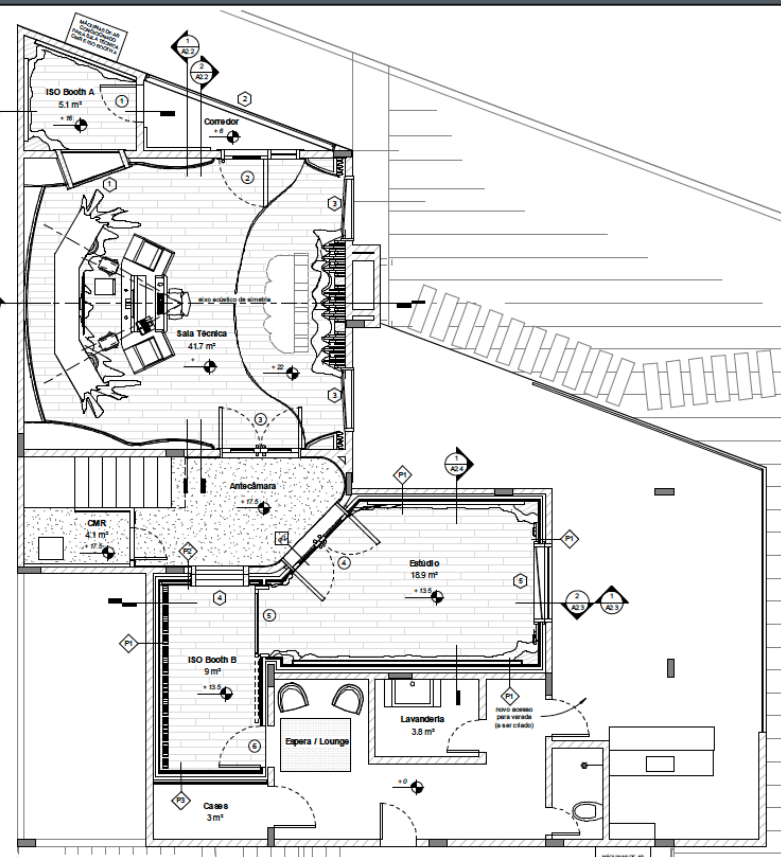



LUÃ SANTANA Home Studio

São Paulo, Brasil



Control Room



Studio



IVETE SANGALO Home Studio

Salvador, Brasil

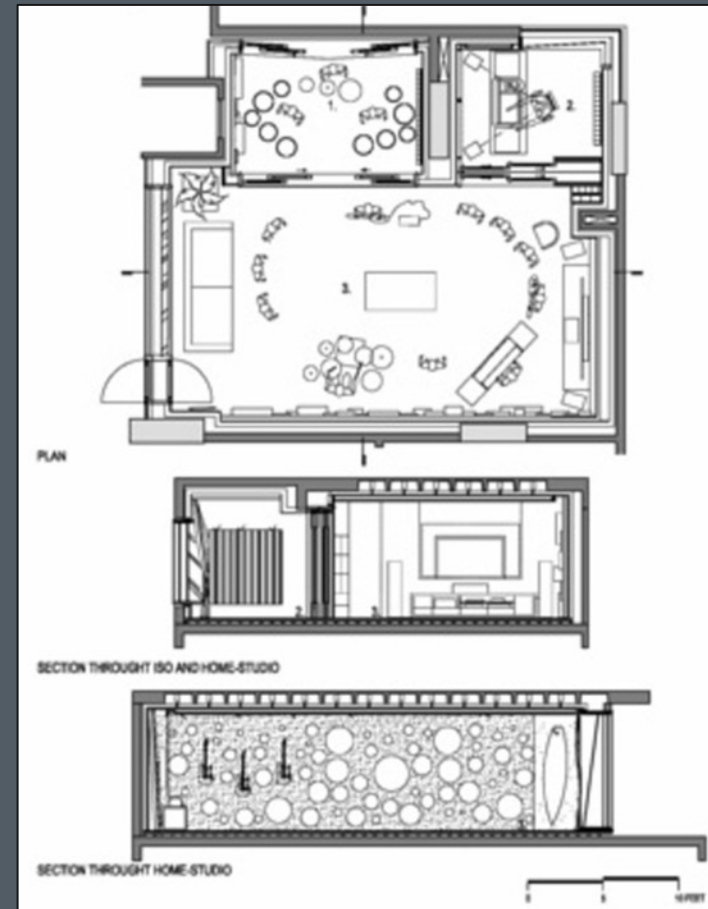
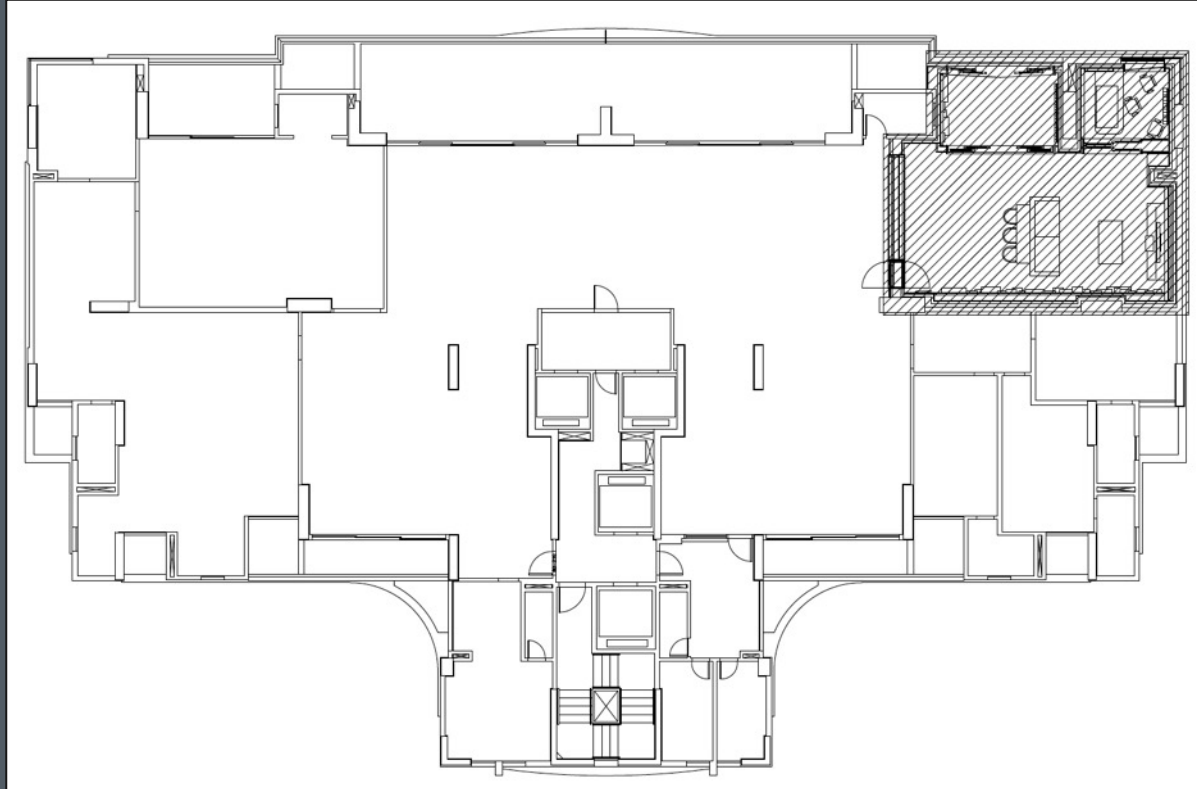



IVETE SANGALO Home Studio

Salvador, Brasil



Studio



Studio



WILD SOUND

Manila, Phillipinas

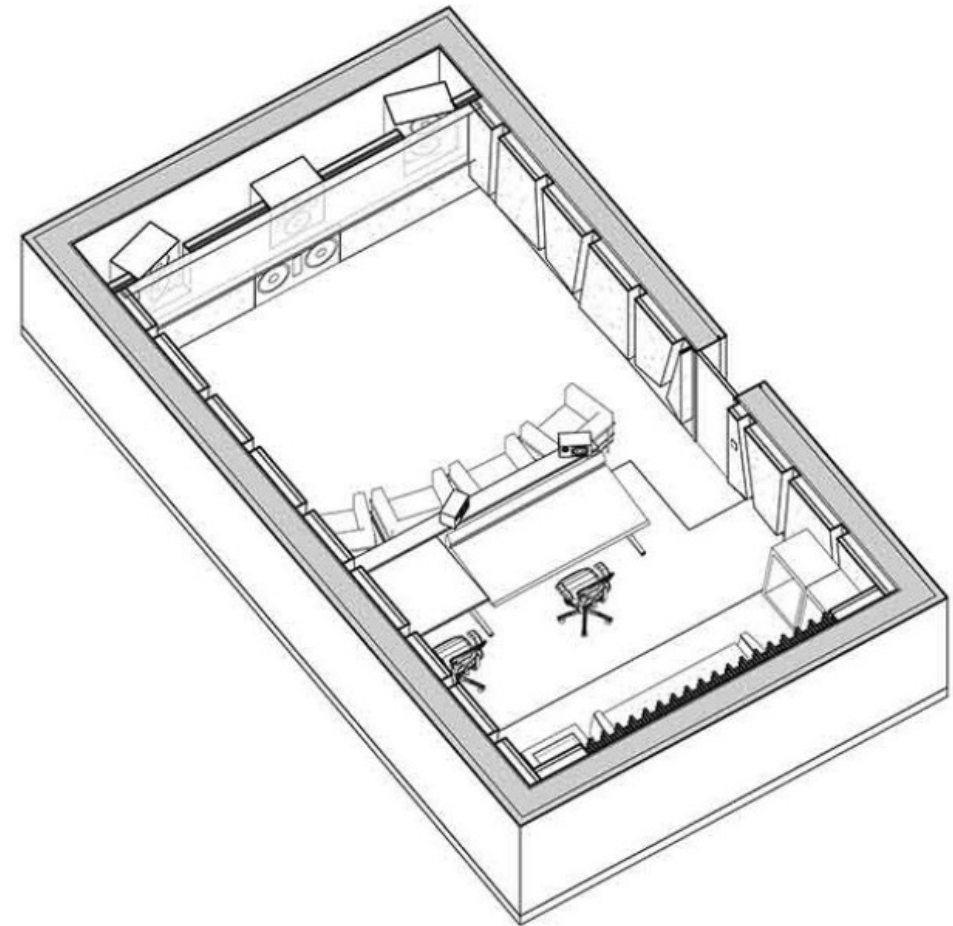
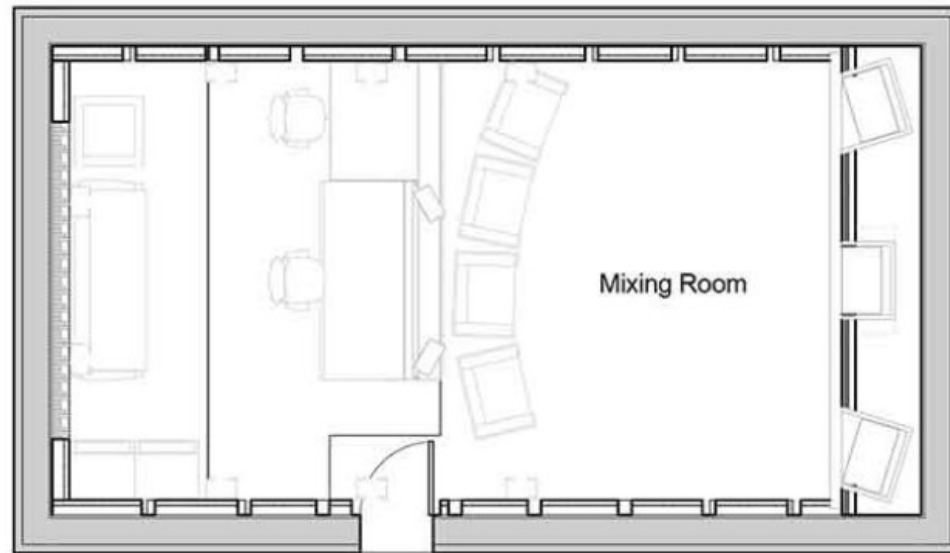



WILD SOUND

Manila, Phillipinas



Dolby Atmos Mixing Theater



GOOGLE YOUTUBE SPACE

Rio de Janeiro, Brasil

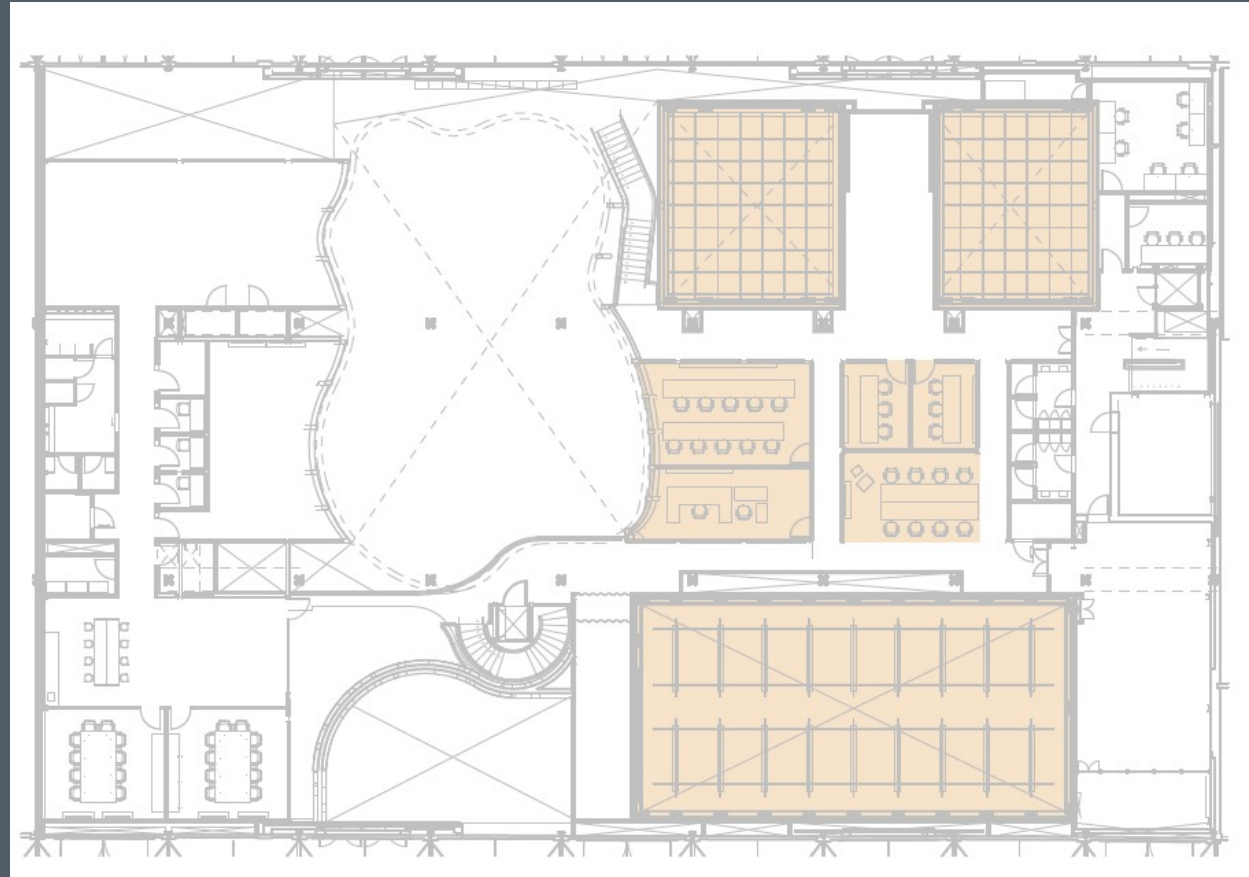
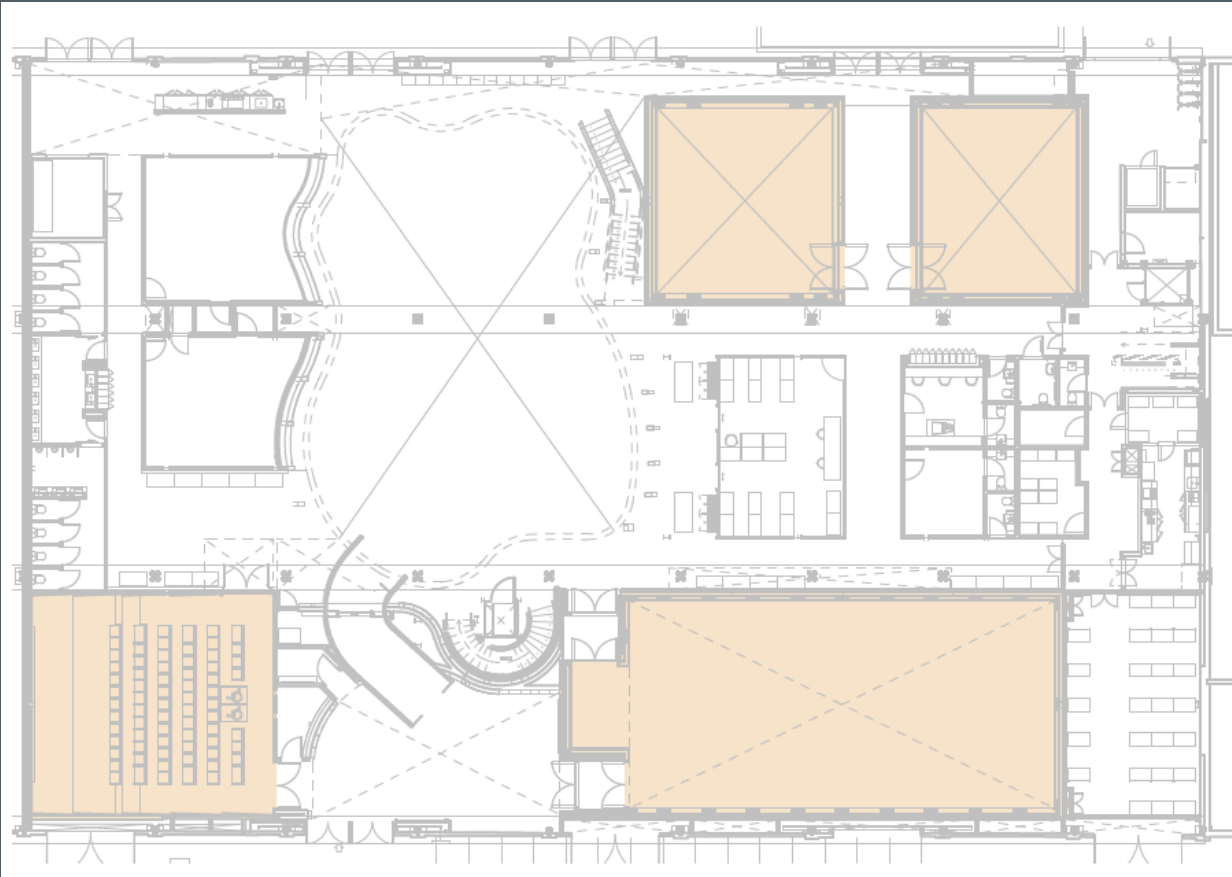



GOOGLE YOUTUBE SPACE

Rio de Janeiro, Brasil



Audio Control Room



Video Control Room



GOOGLE YOUTUBE SPACE

Rio de Janeiro, Brasil



Production Studio 1



Production Studio 2



GOOGLE YOUTUBE SPACE

Rio de Janeiro, Brasil



Screening Room



Edit Station



TV GLOBO - PROJAC

Rio de Janeiro, Brasil

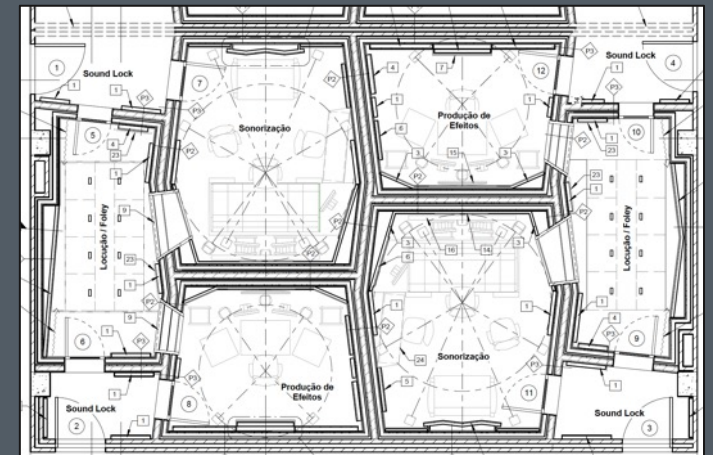
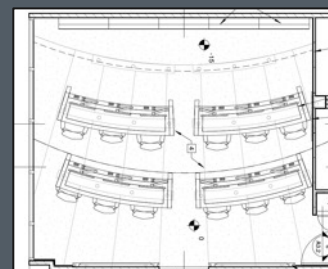
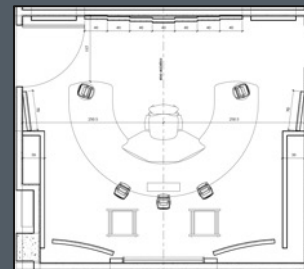
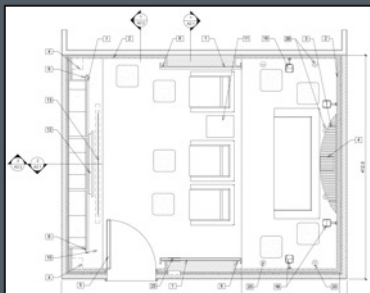
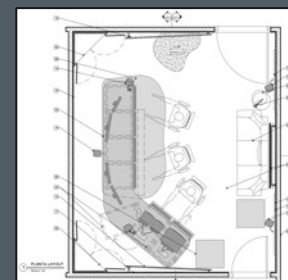
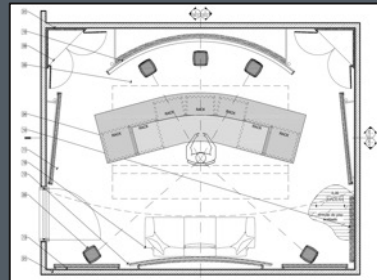
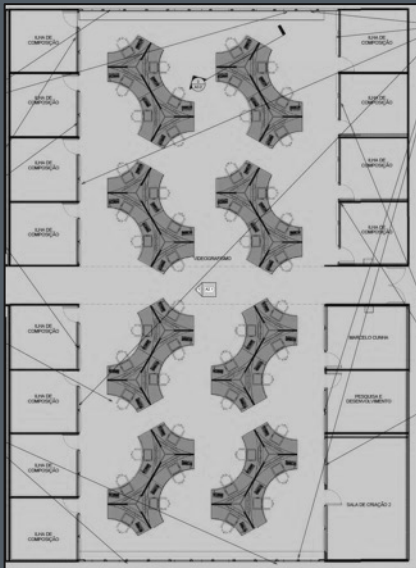
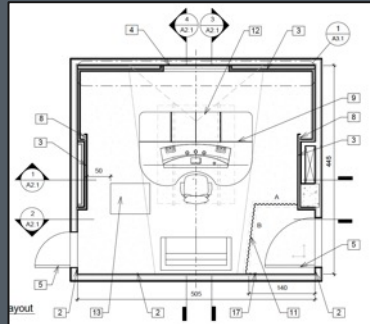
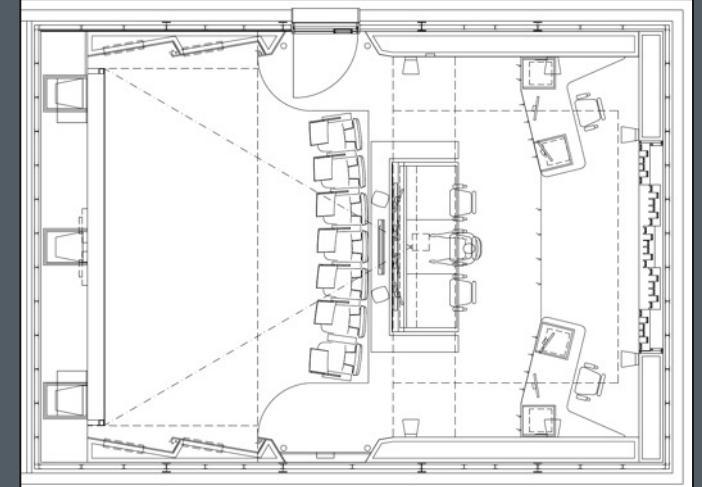
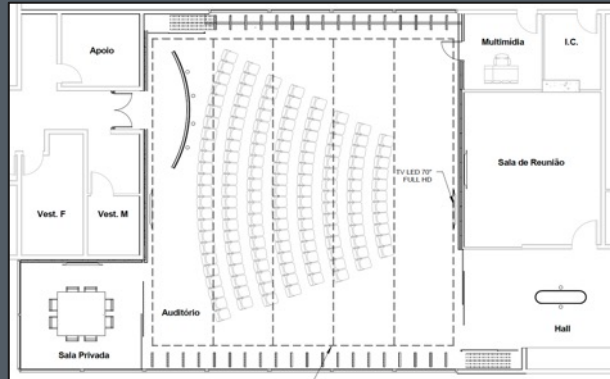
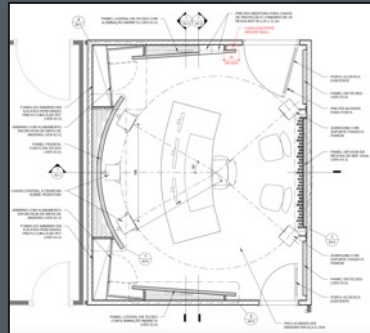



TV GLOBO - PROJAC

Rio de Janeiro, Brasil



Dolby Atmos Mixing Theater



Screening Room



TV GLOBO - PROJAC

Rio de Janeiro, Brasil



Audio Control Room



NOC



TV GLOBO - PROJAC

Rio de Janeiro, Brasil



Mobile Recording Truck



HOME STUDIOS



VICTOR CHAVES

Campinas, Brasil





HAROLDO FERRETTI

Nova Lima, Brasil





MATEUS ASSATO

Campo Grande, Brasil





KAREM ÁVILA
São Paulo, Brasil





IGOR COMÉRIO

Vitória, Brasil





ALEXANDRE LUCENA

Nova Lima, Brasil

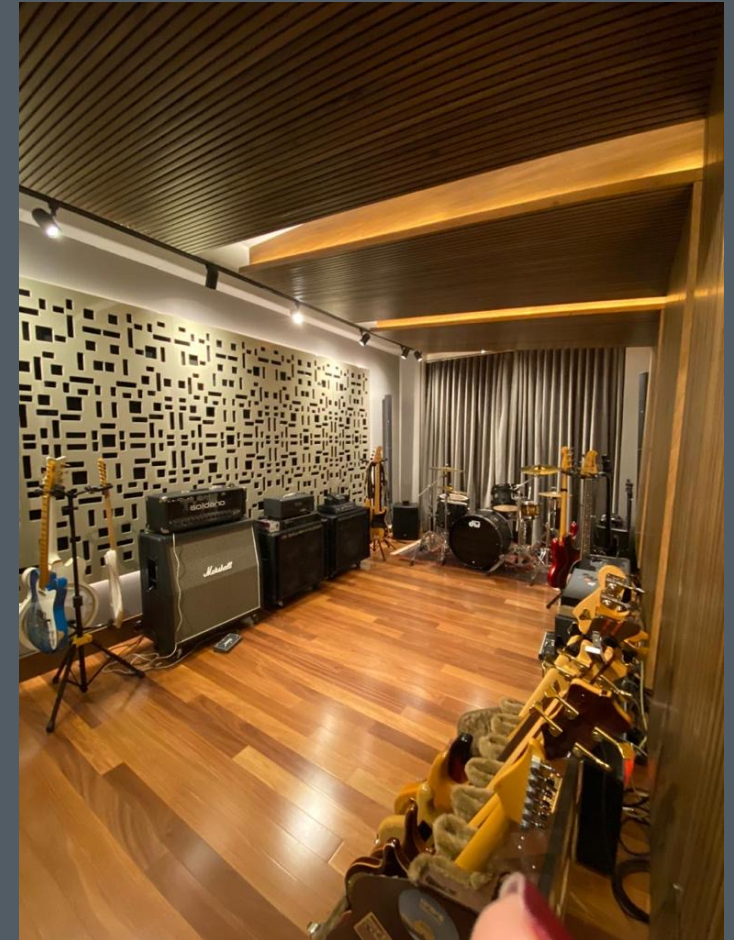
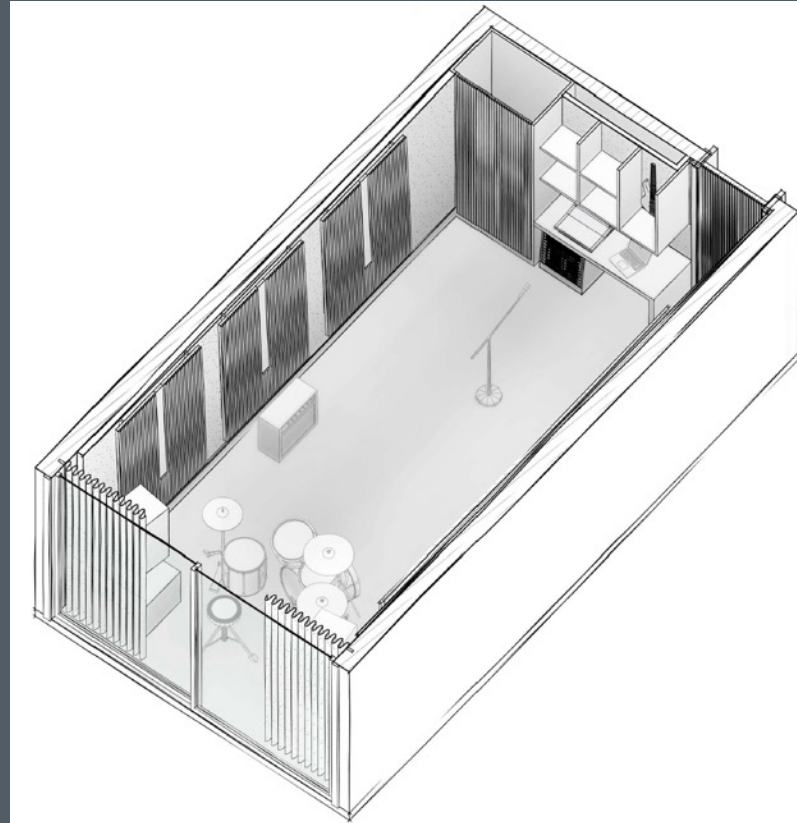



SAMUEL SABARÁ

Valinhos, Brasil





PEDRO VELOSO

Belo Horizonte, Brasil

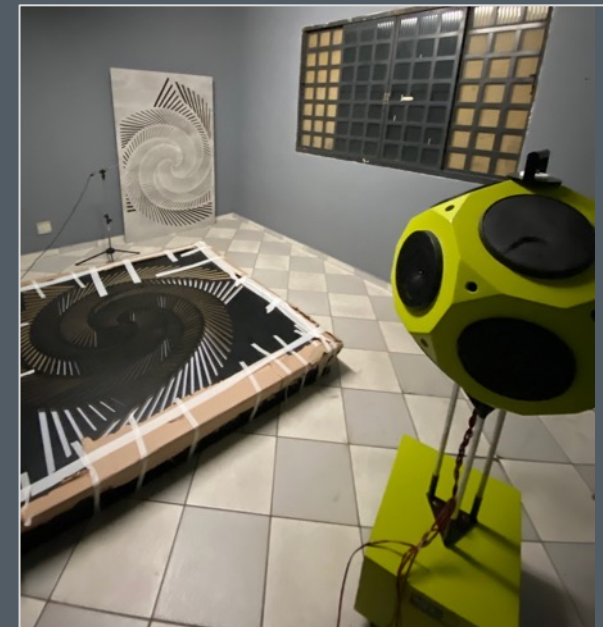
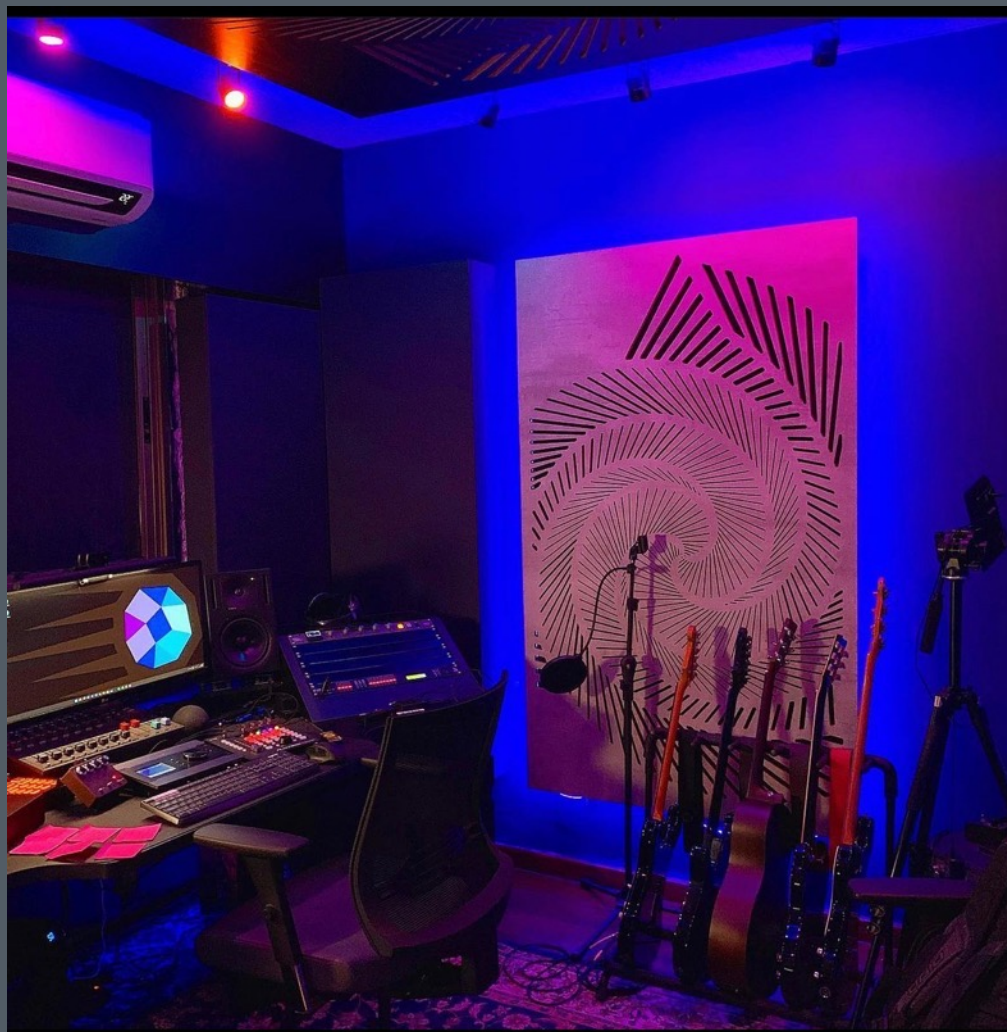
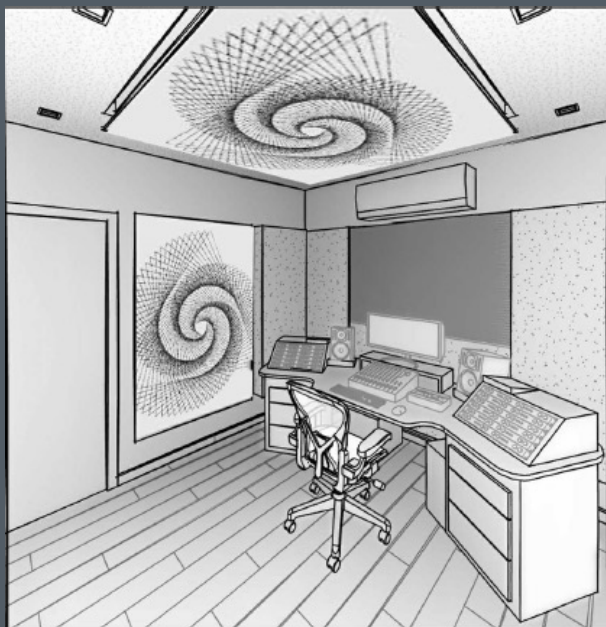

OPERA STUDIOS

Betim, Brasil





PERFORMANCE



ISP PANAMA

Panamá, Panama



Multi Performance Theater



FÁBRICA DE CULTURA DE DIADEMA

São Paulo, Brasil



Multi Performance Theater



GOOGLE – Sede São Paulo, Brasil



Multi Performance Spaces



ESCOLA DE MARKETING INDUSTRIAL

Cotia, Brasil



Multi Performance Theater



MUSEU DO INHOTIM

Brumadinho, Brasil



Multi Performance Theater



AREAN FONTE NOVA

Salvador, Brasil



Festival de Verão 2016



AREAN FONTE NOVA

Salvador, Brasil

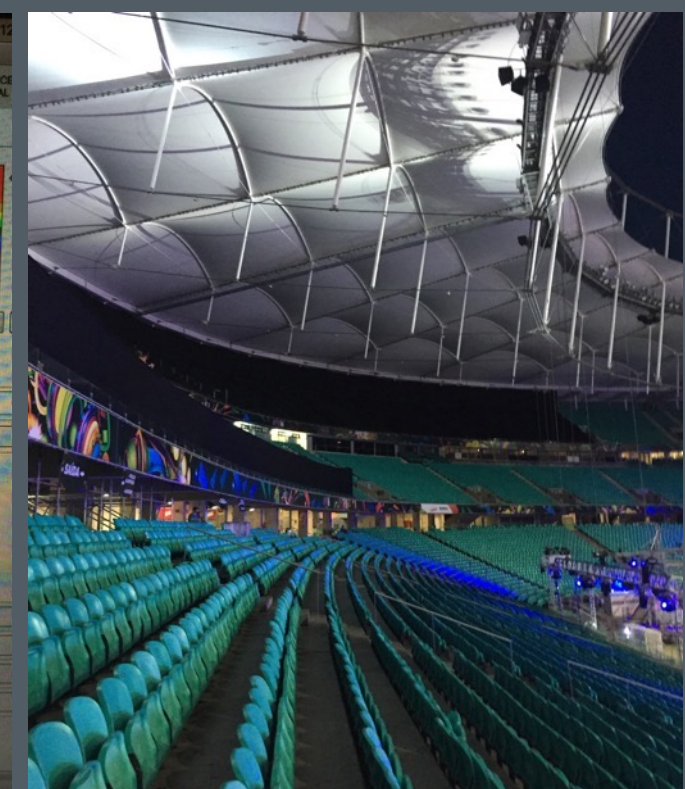
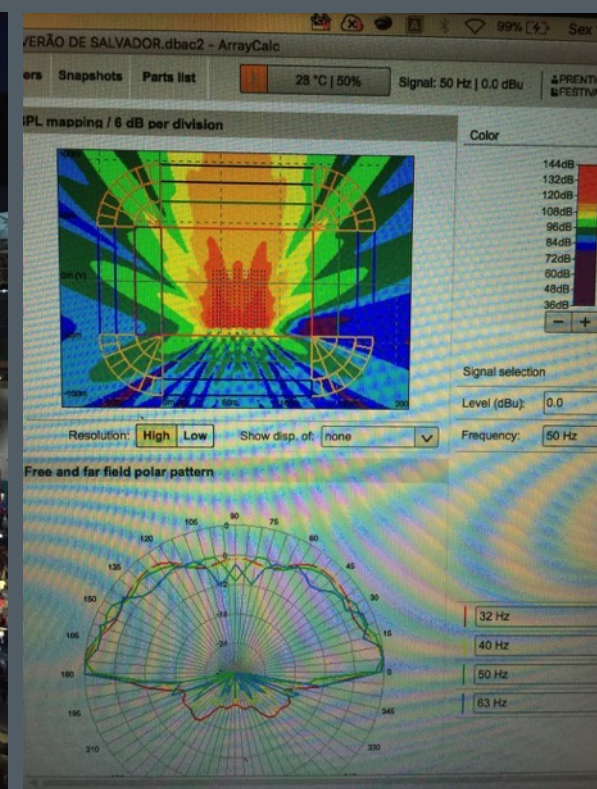

Festival de Verão 2017



GOOGLE YOUTUBE SPACE

Rio de Janeiro, Brasil



Multi-Performance Studio



RESTAURANTE CAC

Belo Horizonte, Brasil





IGREJAS



IGREJA BATISTA CENTRAL

Belo Horizonte, Brasil

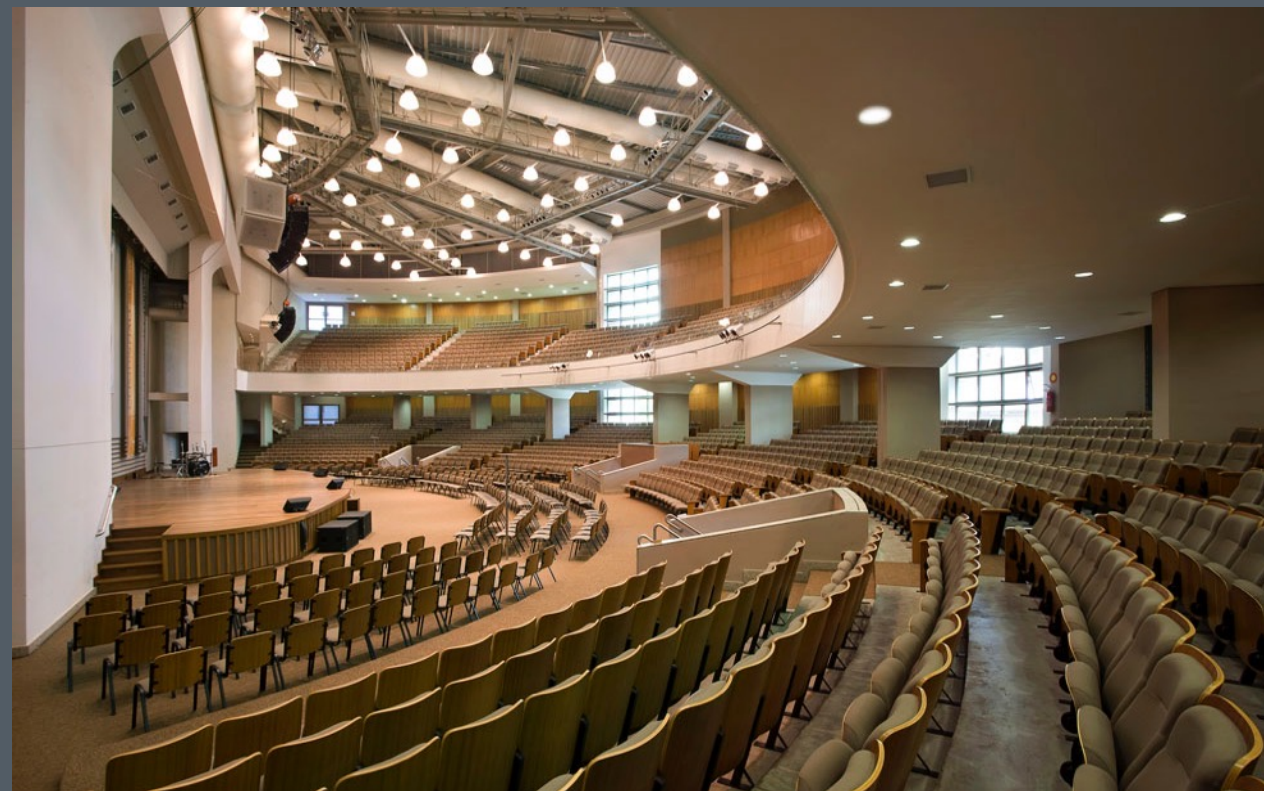



CATEDRAL CRISTO REI

Belo Horizonte, Brasil



Arquitetura Oscar Niemeyer





CATEDRAL NITERÓI

Niterói, Brasil



Arquitetura Oscar Niemeyer

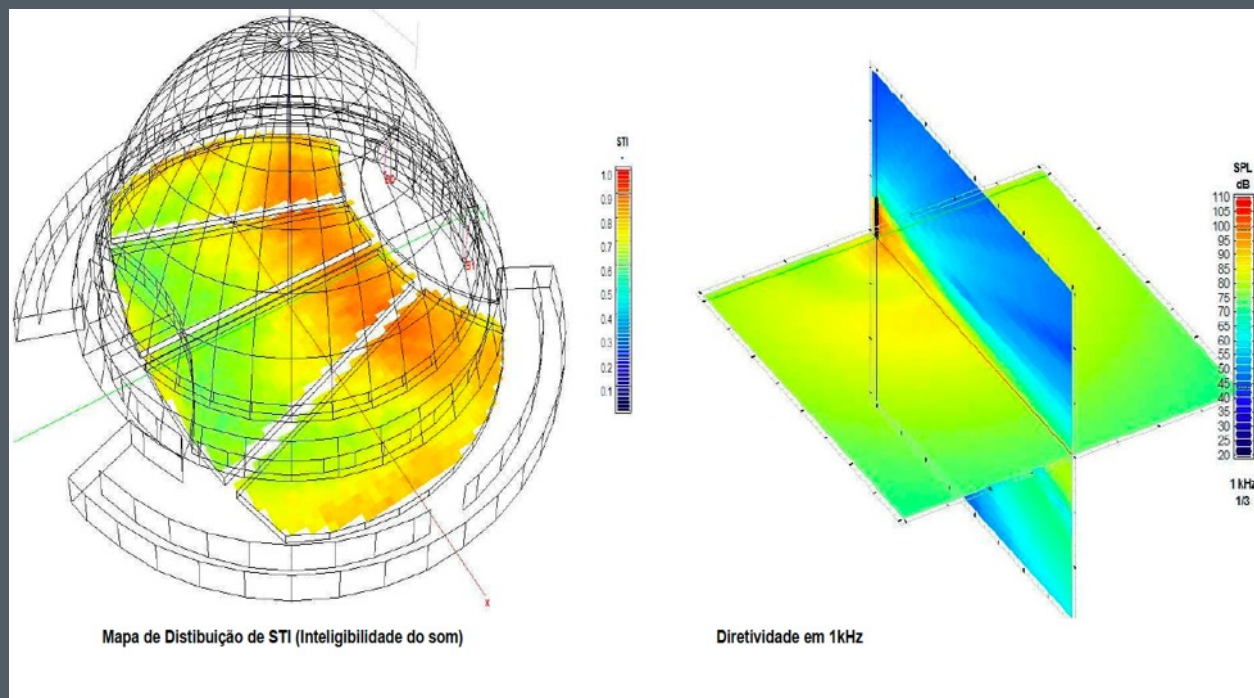



IGREJA BATISTA DE SÃO JOSÉ

São Paulo, Brasil





COMUNIDAD DE FE

Quito, Ecuador

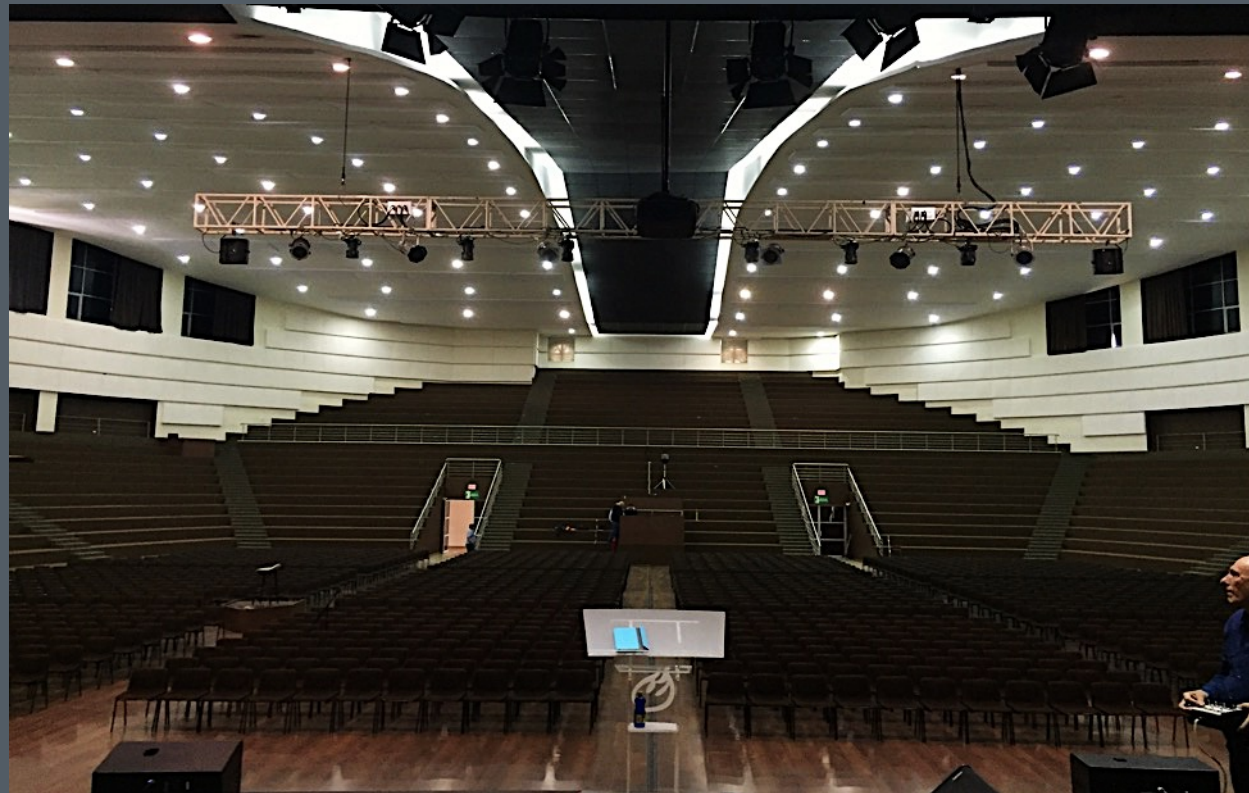



PRIMEIRA IGREJA BATISTA DE CURITIBA

Curitiba, Brasil





IEQ

São Bernardo, Brasil





MIR

Manaus, Brasil





RESIDENCIAL



MHT

Nova Lima, Brasil





RESIDENCIAL

Brumadinho, Brasil





RESIDENCIAL

Nova Lima, Brasil





RESIDENCIAL

Belo Horizonte, Brasil





RESIDENCIAL

Rio de Janeiro, Brasil





RESIDENCIAL

Belo Horizonte, Brasil





RESIDENCIAL

Belo Horizonte, Brasil





RESIDENCIAL

Belo Horizonte, Brasil





RESIDENCIAL

Nova Lima, Brasil





ALINHAMENTO DE SISTEMAS



O Alinhamento de um sistema de som é uma das mais importantes fases de um trabalho de qualquer instalação de áudio. Em Estúdios de Gravação é ainda mais crítico devido ao nível de precisão necessário.

Nenhuma sala é igual à outra, e sempre existe algo que possa ser ajustado para fazer um sistema soar melhor em qualquer tipo de espaço.

É a forma de extrair o melhor de uma sistema de áudio em condições acústicas específicas, harmonizando com o ambiente da maneira mais prazerosa.



“O que mais amo no meu trabalho como designer e engenheiro de som é quando tenho a oportunidade de participar do processo do início ao fim, ficando responsável pelo controle de qualidade fazendo a calibragem no sistema de monitoração para certificar que a performance do sistema será maximizada da melhor forma possível.



RENATO CIPRIANO

SYSTEM TUNING



ELECTRIC LADY STUDIOS, NY



CHURCH STUDIOS, LONDON (Paul Epworth)



DREAM AZYLUM, FL (Nate Hill, Marcela Arayca)



BOSTON SYMPHONY ORCHESTRA (BSO)



NEPTUNE VALLEY, LA – Paul Allen)



JAY COLE

SYSTEM TUNING



DIANTE DO TRONO, BH, BRAZIL



STUDIO 13, MEXICO



JASMIN STUDIO, FORTALEZA, BRAZIL



55 TECH, BEIJIN, CHINA



SONASTÉRIO, NOVA LIMA, BRAZIL



AR STUDIOS, RIO, BRAZIL

SYSTEM TUNING



CLAP STUDIOS, MEDEJIN, COLOMBIA



AUDIBLE, NEWARK



MUCIO RESIDENCE, BRASIL



TV GLOBO, RIO, BRAZIL



PEPSI CO, NY



ZHEJIANG CONSERVATORY, CHINA

SYSTEM TUNING



FC DIADEMA, SP, BRAZIL



NEW DOORS VINTAGE KEYS (NDVK),



55 TECH, BEIJIN, CHINA



GRAPESOUNDLAB, SP, BRAZIL



MINÉRIO DE FERRO (JOTA QUEST), BRAZIL



MONASTÉRIO, GUAIAQUIL, ACUADOR

SYSTEM TUNING



MARACANÁ STADIUM, RIO, BRAZIL



ARENA FONTE NOVA, SALVADOR, BRAZIL



FABRICA DE CULTURA, SAO PAULO, BRAZIL



INHOTIM MUSEUM, BRUMADINHO, BRAZIL



IBC CHURCH, BH, BRAZIL

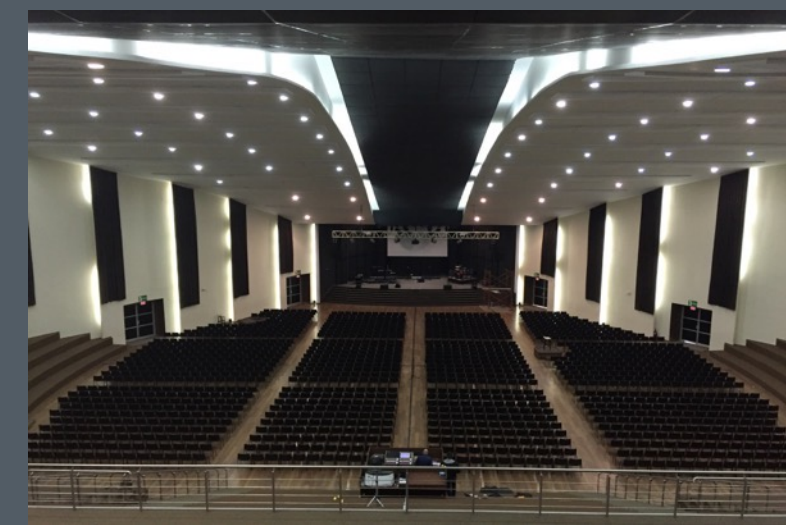

COMUNIDAD DE FE, QUITO, ECUADOR

